

HUGO GERNSBACK
Editor

SHORT WAVE AND TELEVISION

April

WORLD'S
LARGEST
SHORT WAVE
CIRCULATION

Short Waves
Aid
Movie Directors
See Page 730

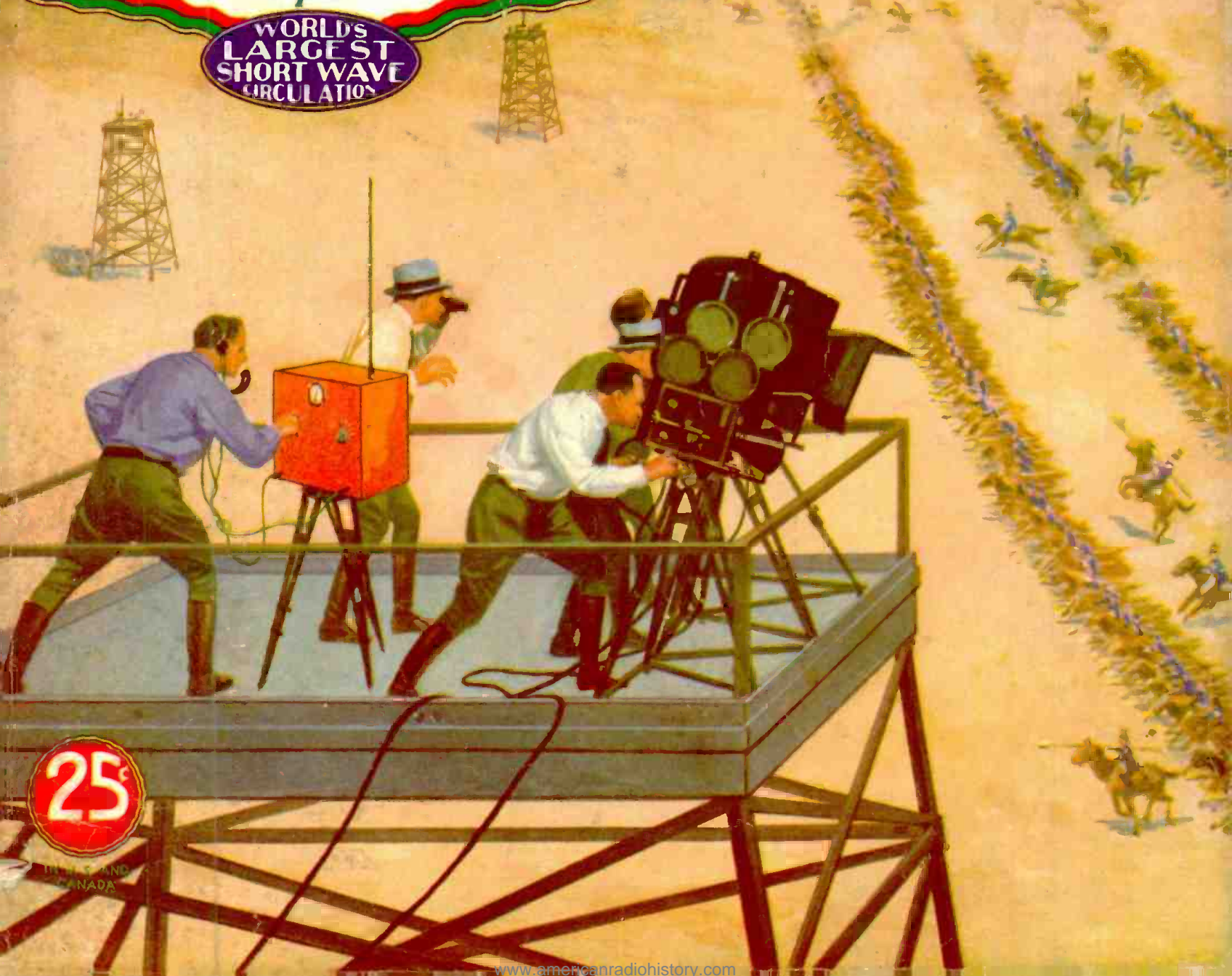

25¢



The Editors Test Them All—They Know

"—GAVE A SURPRISING ACCOUNT OF ITSELF DURING TESTS BY THE EDITORS—A TRULY MODERN APPLICATION OF REGENERATION PRINCIPLES—OFFERS OPERATING REFINEMENTS COMPARABLE WITH THOSE OF MUCH HIGHER PRICED SUPERHETERODYNES."—RADIO NEWS (February, 1937)

"FEW IF ANY SETS TODAY ARE AS VERSATILE AS THIS NEW R-S-R CLIPPER."—THE NEW YORK SUN (Jan. 16, 1937)

A SHORT WAVE COMMUNICATION RECEIVER

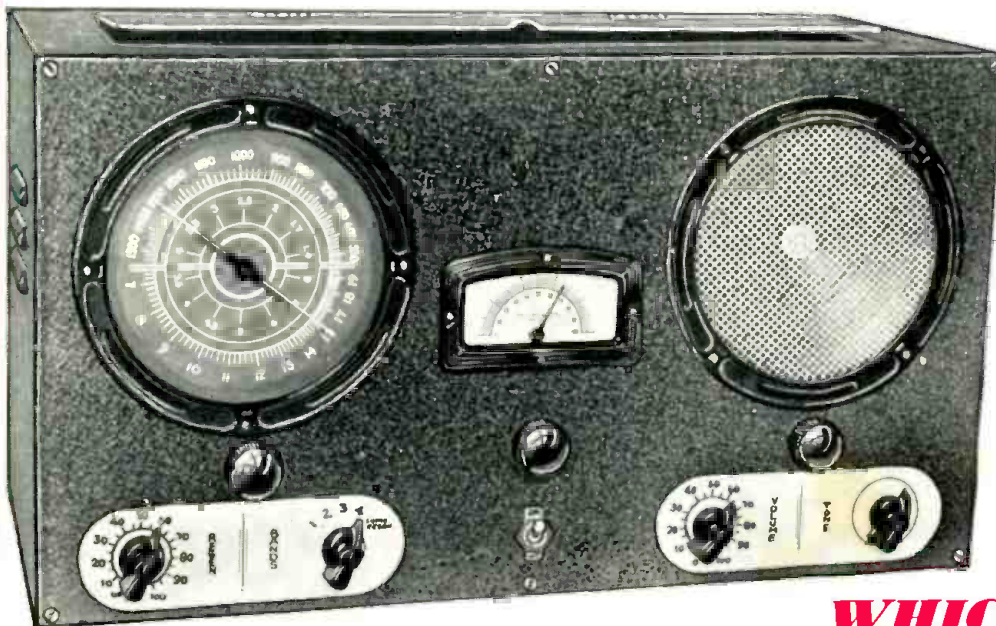

TUNES FROM
3 TO 555 METERS

Uses
Five Highly
Efficient Tubes

with
BEAM-POWER
OUTPUT

and
E-X-T-R-E-M-E
BANDSPREAD

WHICH PLACES THE WORLD AT YOUR FEET!

THE new R-S-R CLIPPER is a beautiful big All-Band receiver (18"x10"x8") built for the personal use of the man who likes to explore the world via the high and ultra-high frequencies. Here is one of our many unsolicited testimonials recently received from an R-S-R CLIPPER owner in Roselle, N.J., which speaks for itself:—

"Gentlemen:—A week ago I purchased one of your R-S-R Clippers. I tried it for a week and am willing to tell you how it compares with the old R-S-R receiver which I have been using for about nine months.

"Never have I heard a five tube receiver with so little AC hum; it is almost inaudible, even with phones. The 6L6 tube in the amplifier circuit gives such tremendous 'punch' that it is often necessary to cut down the volume control by half on some of the more powerful European stations. . . .

"The regeneration control is beautifully smooth on all bands. The band-spread is also a very welcome feature, especially on the 20 meter amateur band where stations are very crowded and hard to separate on a regular dial.

"During the week in which the receiver has been in use I have jotted down all stations received in the few hours of listening done each day. I am inclosing the list which includes 43 stations in 22 foreign countries (does not include amateurs or American stations). . . . [The list enclosed included 4 different Russian stations, Iceland, Austria, Japan, Australia, Czechoslovakia, etc.] Signed: Mr. Wm. Winkler, 1023 Warren Street, Roselle, N.J."

Mr. Winkler has kindly consented to allow us to use his letter which we have done, feeling that the actual experience of a typical DX listener with the R-S-R CLIPPER is of more interest to you than anything we could tell you about this receiver.

The CLIPPER circuit makes use of five highly efficient tubes, only one of which is a metal tube (this is the radio frequency amplifier which must be well shielded and is the new Isolantite insulated 6K7 super-control pentode). The new 6J5G high frequency tubes are used in the detector and first audio positions while a glass 6L6 Beam Power tube supplies the output power to the heavy duty 6" dynamic speaker. The old reliable 80 tube is used as rectifier.

HAYNES R-S-R CLIPPER
complete with 5 Sylvania
tubes ready to plug in to
A.C. outlet and operate
Shipping weight 20 lbs.

\$28⁸⁵

Always on demonstration at our laboratory or dealers.

RADIO CONSTRUCTORS LABORATORIES
Dept. SW-4, 136 LIBERTY ST., NEW YORK, N. Y.

RACO
PRODUCTS

RACO
PRODUCTS

**RCA ALL
THE WAY**

RCA Radio News

RCA Manufacturing Company, Inc. • Camden, New Jersey
A Service of the Radio Corporation of America

**EVERYTHING IN
RADIO—MICROPHONE
TO LOUDSPEAKER**

To the consumer, RCA means high quality performance at low cost . . . To the radio man, RCA means easier selling, higher profits

NEW STREAMLINED "MIKE"!

RCA "Aerodynamic" Microphone combines small size with fine performance!



SPECIFICATIONS:

- Type . . . Pressure Operated.
- Frequency Range . . . 100 to 6000 cycles.
- Impedance . . . 250 ohms.
- Average Operating Level -68 db (10 bar signal across open circuit).
- Dimensions . . . 2 1/2" wide, 3" high, 3 3/4" deep.
- Net weight . . . 1 1/4 pounds.
- Finish . . . polished chromium.
- Cable . . . 6 feet shielded cable.
- Stand Fitting Size . . . 3/8" pipe thread.

RCA's new Aerodynamic Microphone, MI-6226—the pressure operated dynamic type—is small enough to fit the hand, light enough to carry easily, and offers outstanding performance!

ance! It is ideal for normal public address work and particularly suited for close talking.

This new "mike", handsomely streamlined, gives excellent frequency response, insuring truly natural tone reproduction and clarity of speech. Its new Alnico permanent metal magnet provides maximum sensitivity and extra long magnet life. In addition, it makes the use of external excitation or power unnecessary.

Besides these features, the RCA Aerodynamic Microphone also offers many others, listed below for your convenience. Look them over. They'll convince you that there's plenty of microphone quality packed beneath the attractive chrome covering!

NOTE THESE FEATURES!

- Small size • Light Weight • High Sensitivity • No external excitation of power supply required • Rugged construction—insensitive to mechanical vibration.
- Unaffected by changes in temperature, humidity or barometric pressure • May be operated at distances up to 1000 feet from amplifier • Excellent for close talking • Practically non-directional when faced vertically • Minimum response to wind • New Alnico metal magnet—retains magnetism indefinitely. List Price, \$26.50



ACR-155 . . . New, Low-Cost General Purpose Communications Receiver
Amateur's Net \$74.50 f.o.b. factory

2 RCA Amateur Receivers Answer Price and Performance Problems!

This receiver brings superior performance under modern operating conditions—yet sells at exceptionally modest cost! A number of its features are not to be found in other receivers costing so little. The outstanding features include continuous frequency coverage from 520 to 22,000 kcs... 9 Metal RCA Radiotrons for improved high-frequency performance... improved, large tuning knob with crank handle for easy tuning... 100 to 1 band spread tuning drive... improved, adjustable, air-dielectric trimming capacitors... magnetite-core i-f transformers... calibration-spread dial for accurate logging... electrically stabilized oscillators.

ACR-175 . . . New, Multi-Feature Communications Receiver... An Outstanding Value!

Amateur's Net \$119.50 f.o.b. factory

This excellent instrument presents a combination of advanced features not even found in receivers selling at much higher prices!

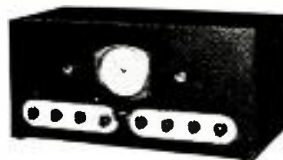

Its keen selectivity, plus a specially designed crystal filter, makes separation of interfering stations easy—even in the most crowded amateur bands.

Among its 32 performance features is an unusual tuning range—500 to 60,000 kcs.—giving coverage of many services unreachd by other communications receivers. Has 11 tubes, two stages of high-gain i-f amplification and a smooth-handling, single control band spread system for easy tuning and accurate logging without use of reference points.

Convert Your Radio Into Phonograph-Radio at Low Cost!

You can do it with the smart RCA Victor Record Player illustrated here! This fine instrument easily and quickly attaches to any electrically operated radio and in a jiffy turns it into an electric phonograph-radio combination! With it, you can hear all your favorite radio programs PLUS recorded music!



Its small size means you can conveniently place it in any small place. And it's yours for less than \$20, in a fine walnut finish. Or you can get it in red, black or ivory for just a few dollars more.

RCA Victor also offers great values in new, 1937 radios! There are many new models and prices, plus a fine array of performance features including Magic Voice, Magic Brain, Magic Eye, Metal Tubes. And in addition—with an RCA Victor set you enjoy the extras of radio that's RCA ALL THE WAY—instruments created by the same men who build big broadcasting studios! Hear these new radios today. Their beautiful cabinets will more than please you. Easy C. I. T. time payments.

LATE NEWS FLASH!
1936 RCA Metal Tubes Sales Double Those of 1935!
Extra quality of RCA Tubes boosted 1936 sales to double the millions sold in 1935.

Please mention SHORT WAVE & TELEVISION when writing advertisers

IN THIS ISSUE: PROMINENT SHORT-WAVE AND TELEVISION AUTHORS

Zworykin • Eckhardt • McEntee • Shuart • Denton • Palmer • Kennedy • DeRosa



HUGO GERNSBACK
Editor

H. WINFIELD SECOR
Managing Editor

GEORGE W. SHUART, W2AMN
Associate Editor

Combined With
Official SHORT WAVE LISTENER

Contents for April, 1937

Editorial—Television and the Electron, by Dr. Vladimar K. Zworykin.....	725
Television in Europe.....	726
“Ham” License Test Easy—Says Robert Hertzberg, Who Took the Examination.....	727
Amateur Radio and the Flood.....	727
President Thanks Hams—Short Waves at Inauguration.....	728
Television Course, Lesson 3, by George H. Eckhardt.....	729
S-W’s Aid Movie Directors.....	730
PCJ, Eindhoven, Has Novel Voice Recorder.....	730
Low-Cost Oscilloscope, Part 2, by Howard G. McEntee.....	731
A 5-Meter A.C.-D.C. Receiver, by Jack Barnette, W3-GHQ.....	731
Short-Wave Beginner—A Simple 1-Tube Receiver. \$25.00 Prize Contest, by George W. Shuart, W2AMN.....	732
Sr. Space Explorer, by H. G. Cisin.....	734
Is Your Receiver Top-Notch?, by Clifford E. Denton.....	735
One Meter Waves for “Short Haul” QSO’s, by George W. Shuart, W2AMN.....	736
Short Wave League—“When to Listen In,” by M. Harvey Gernsback.....	738
World-Wide Short-Wave Review, Edited by C. W. Palmer.....	739
Short Wave Scouts—Thirty-Seventh Trophy.....	740
Short Waves and Long Raves.....	741
\$5.00 for Best Short-Wave KINK.....	742
What’s New in Short-Wave Apparatus—RSR Clipper, by A. J. Haynes.....	743
The “Sky-Challenger”—Range 38.1 mc. to 545 kc.....	744
Hams Will Find These New Tubes Useful.....	745
Additional Features in New “Super Pro.,” by Donald Lewis.....	745
A Crystal-Controlled 5 and 10-Meter Transmitter, by Maurice E. Kennedy, W6KQ-W6BGC.....	746
“Movie Dial” Projects Call Letters on Screen.....	748
How to Build a “Volume Expander” That Works, by L. A. de Rosa, E. E.....	748
World S-W Station List, by M. Harvey Gernsback.....	749
Let’s “Listen In” with Joe Miller.....	754
Short-Wave QUESTION BOX.....	755
Diagrams of Commercial S-W Receivers.....	756

Certified Circuits



● **SHORT WAVE & TELEVISION** goes to a large expense in verifying new circuits. When you see this seal it is your guarantee that such sets have been tested in our laboratories, as well as privately, in different parts of the country. Only “Constructional-Experimental” circuits are certified by us.

When you see our certified seal on any set described, you need not hesitate to spend money for parts, because you are assured in advance that the set and circuit are bona fide and that this magazine stands behind them.

SHORT WAVE & TELEVISION is the only magazine that certifies circuits and sets.

OUR COVER

● **THIS** month the front cover picture shows how short-wave transmitting and receiving sets may lend their valuable aid to the making of a great motion picture, such as “The Charge of the Light Brigade.” Short-wave phone sets enable the director and his assistants to keep in communication with each other at all times. For details see page 730.

COPYRIGHT, 1937, BY H. GERNSBACK

Published by **POPULAR BOOK CORPORATION**

401 N. Wesley Avenue, Mount Morris, Ill.

Editorial and Executive Offices - - - - 99-101 Hudson St., New York, N. Y.
HUGO GERNSBACK, President - - - - **H. W. SECOR**, Vice-President
EMIL GROSSMAN - - - - - Director of Advertising
 European Agent: Gorrings American News Agency, 9A Green St., Leicester Square, London W. C. 2
 Australian Agents: **McGILL’S AGENCY**, 179 Elizabeth St., Melbourne

Features in the May Issue

Compact 150-watt Transmitter Using RK-37’s—A rig that will interest every “Ham.”

2½ to 200-Meter Receiver for the Beginner—On this set you can hear the 5-meter Amateur and television signals, listen in on the 10,000 mile DX; Amateur QSO’s on the 10-meter band, and, besides, receive all the “foreign” short-wave stations.

Television Advances in Europe and America—Illustrated with newest photos and data.

A 2-Tube Receiver for the S-W Fan—It operates on batteries and has a “band-switch.”

How to Record Short-Wave Programs, by James L. Fouch.
 5-Tube All-Wave Superhet, by Harry D. Hooton, W8KPX.

SHORT WAVE & TELEVISION—Monthly. Entered as second-class matter May 7, 1930, at the post office at Mount Morris, Illinois, under the act of March 3, 1879. Trademarks and copyrights by permission of H. Gernsback, 99-101 Hudson St., N. Y. C. Text and illustrations of this magazine are copyrighted and must not be reproduced without permission. **SHORT WAVE & TELEVISION** is published on the 1st of every month. Twelve numbers per year. Subscription price is \$2.50 a year in the United States and possessions and Canada. Foreign countries, \$3.00 a year. Single copies 25c. Address all contributions for publication to Editor, **SHORT WAVE & TELEVISION**, 99-101 Hudson St., New York, N. Y. Publishers are not responsible for lost manuscripts. Contributions cannot be returned unless authors remit full postage. **SHORT WAVE & TELEVISION** is for sale at all principal newsstands in the United States and Canada. European agents: Brentano’s, London and Paris. Printed in U. S. A. Make all subscription checks payable to Popular Book Corporation.

TRIPLED MY PAY

Working steady... Making three times money I was... before I took up Coyne Training—*Bert Farley.*



\$300 A MONTH

Two weeks after graduation I had job with large Electrical Co. at \$300 a mo., with car furnished—*H. C. Omer.*



THANKS TO COYNE

I secured a position with an Electrical Construction Company, paying me three to four times more a week than I was getting before I entered Coyne—*J. O. Whitmeyer.*



THOUSANDS are MAKING
\$30-\$40-\$50 a WEEK
in **ELECTRICITY**
Huge Developments Ahead
LEARN BY DOING —
12 WEEKS TRAINING IN BIG COYNE SHOPS



Thousands of Trained Electrical Men are making good money in the many branches of Electricity. Train for a better job—Right NOW!—whether you're 16 or 40. Look about you. Industry everywhere is being modernized with new electrical equipment—will use more ELECTRICITY. Many power plant operators now make up to \$50 a week. Electrical Maintenance Men are paid \$150 a month and up. Refrigeration and Air Conditioning Service Men earn \$30—\$40—\$50 a week. Armature winders make \$40 a week and more. Aviation Ignition Men also make good money at steady jobs. Many others operate their own business. These are only a few of the opportunities in Electricity.

COYNE extends the helping hand to YOU, too, if you're in a low-pay, discouraging job. Break out of the untrained class! If you are interested in bettering your place in life, get into ELECTRICITY—the gigantic growing field that employs more men than any other industry on earth!

**Train on FULL SIZE Equipment—
NOT by Correspondence—NOT by Text Books**

COYNE Shop Training is NOT by correspondence or Home Study. You come right to the big COYNE Shops in Chicago to get this practical Training. You work on real equipment—such as generators, real dynamos, you wind armatures, work on diesel engines, airplane motors, and do many other practical Electrical jobs. Here is one of the greatest working outlays of its kind in America. No embarrassing reciting. No dry text books. You don't need high school education or previous experience. It is this real job Training that enables COYNE to train you for a better pay job.

**AIR CONDITIONING, DIESEL and
ELECTRIC REFRIGERATION included**

Spreading over the nation is a vast network, these fast developing branches of ELECTRICITY are employing more men and paying more in salaries every year. Homes, offices, factories, trains, autos, airplanes are being air-conditioned. Autos may soon be diesel-powered. Instruction in these courses included without extra cost.



YOU TRAIN HERE
 Many thousands of dollars worth of real practical equipment and machinery is installed in our fireproof modern school.

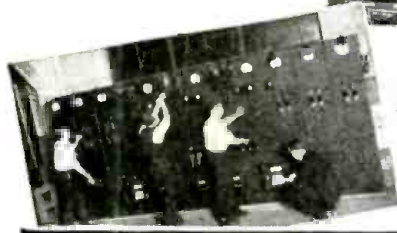

Many shop views like this shown in my catalog



**Send for EASY PAYMENT PLAN
—New Low Cost Board and Room Plan**

My friend, don't waste the golden years of your life saying, "I can't afford Specialized Training!" Of course you can! Get my catalog—see for yourself how we help graduates year after year. I have a special new low cost Board and Room Plan whereby students take care of their living expenses while at COYNE. Get training first, then pay tuition in 18 easy, monthly payments, starting 5 months after you begin school. So don't let lack of money keep you from sending this coupon for full details of my amazing plans!

PART TIME EMPLOYMENT

If you need part time work to help pay living expenses while here, we'll help you. We help hundreds of students through this special department and may be able to help you.

JOB AFTER GRADUATION SERVICE

We keep in touch with many large firms in many branches of ELECTRICITY, ready at all times to supply their needs for trained men. After you graduate you get Lifetime job assistance through our Free Employment Department. As a COYNE graduate you get free business service and technical consultation to help you as you advance in your job; also, the privilege of review at any time without additional tuition charge.

Employers PRAISE These COYNE Graduates

"Mr. Lingerfelt's services very satisfactory. His practical shop training at COYNE has certainly helped increase his efficiency."

"John Lindquist was given an increase in salary due to the high quality of his work."

(Names of companies on request). We have scores of such letters. Get complete story. You owe it to yourself. Clip and send Coupon—NOW!

GET FULL FACTS

You'll see everything in the Big FREE COYNE Book... facts... opportunities... jobs... salaries... actual photos of hundreds of ambitious fellows preparing for better jobs. You'll see proof that COYNE training pays. This big Book is yours without obligation. So act at once. Just mail Coupon.



MAIL THIS NOW
for MONEY MAKING DETAILS

H. C. LEWIS, President,
 COYNE ELECTRICAL SCHOOL,
 500 S. Paulina St., Dept. 47-83, Chicago, Ill.
 Without obligating me, send full details and your Big FREE Illustrated Catalog.

Name..... Age.....
 Street.....
 Town..... State.....
 Mail in Envelope or paste on Postcard

COYNE ELECTRICAL SCHOOL
 H. C. LEWIS, President
 500 S. Paulina Street Dept. 47-83 Chicago, Illinois

Please mention SHORT WAVE & TELEVISION when writing advertisers

Here are the Six BEST SHORT-WAVE RADIO BOOKS!

Without doubt you will have to go a long way to buy better books on short waves than you find on this page. Each book is written by a well-known authority on short waves . . . each book has been carefully illustrated with photographs and diagrams to

make the study of this field of radio much simpler. The volumes on this page are the finest books on short-waves which are published anywhere today. Order one or more copies today . . . find out for yourself how fine they are. Prices are postpaid.

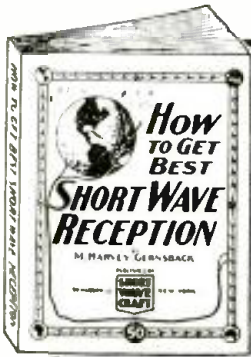

How to Get Best Short-Wave Reception

By M. HARVEY GERNSBACK

This book tells you everything you ever wanted to know about short-wave reception. The author, a professional radio listener and radio fan for many years, gives you his long experience in radio reception and that goes with it. Why is one radio listener enabled to pull in stations from all over the globe, even small 100 watters, 10,000 miles away, and why is it that the next fellow, with a much better and more expensive equipment, can only pull in the powerful stations that any child can get without much ado? The reason is intimate knowledge of short waves and how they behave. Here are the chapters of this new book:

1. What are Short Waves and what can the listener hear on a short-wave receiver or converter?
2. How to tune and when to listen in on the short waves.
3. How to identify short-wave stations.
4. Seasonal changes in short-wave reception.
5. Types of receivers for short-wave reception.
6. Aerial systems for short-wave receivers.
7. Verifications from short-wave stations.

The book makes excellent reading matter. There are men? tricks in short-wave reception that even some of the "old-timers" do not know. Be sure to get it.

40 Illustrations, 72 Pages. **50c**
Stiff, flexible covers

HOW TO BUILD AND OPERATE SHORT-WAVE RECEIVERS

THIS is the best and most up-to-date book on the subject. It is edited and prepared by the editors of SHORT WAVE & TELEVISION, and contains a wealth of material on the building and operation, not only of typical short-wave receivers, but short-wave converters as well. Dozens of short-wave sets are found in this book, which contains hundreds of illustrations; actual photographs of sets built, hookups and diagrams galore.

This book is sold only at a ridiculously low price because it is our aim to put this valuable work into the hands of every short-wave enthusiast.

We know that if you are at all interested in short waves you will not wish to do without this book. It is a most important and timely radio publication.

150 Illustrations, 72 Pages. **50c**
Stiff, flexible covers

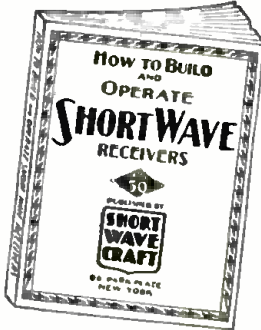

THE SHORT-WAVE BEGINNER'S BOOK

HERE is a book that solves your short wave problems—leading you in easy stages from the simplest fundamentals to the present state of the art as it is known today. It is the only low-priced reference book on short waves for the beginner. The book is profusely illustrated—it is not "technical." It has no mathematics and no technical jargon. It also gives you a tremendous amount of important information, such as time conversion tables, all about aerials, noise elimination, all about radio tubes, data on coil winding and other subjects.

Partial List of Contents

Getting Started in Short Waves—the fundamentals of electricity. Symbols, the Short Hand of Radio—how to read schematic diagrams. Short Wave Coils—various types and kinds in making them. Short Wave Aerials—the points that determine a good aerial from an inefficient one. The Transposed Lead in for reducing static. The Beginner's Short-Wave Receiver—a simple one tube set that anyone can build. How to Tune the Short-Wave Set—telling the important points to get good results. Audio Amplifiers for S-W Receivers. Learning the Code—for greater enjoyment with the S-W set. Wave length to Kilocycle Chart. Wire Chart—to assist in the construction of coils.

75 Illustrations, 40 Pages. **25c**
Stiff, flexible covers

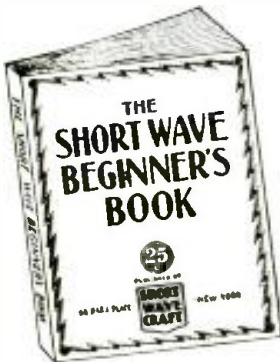

101 SHORT-WAVE HOOKUPS

Compiled by the Editors of SHORT WAVE & TELEVISION

EACH and every hook-up and diagram illustrated is also accompanied by a thorough explanation of what the particular hook-up accomplishes, what parts are required, out-winding information, values of resistors, etc., in fact, everything you want to know in order to build the set or to look up the data required. To be sure, all of the important sets which have appeared in print during the past five years are in this valuable book. Sets such as the Doerle, Littman, the "101" Simplex, "Oscillo-Dyne, Denton "Stand-by," Magalyne Triplet 2, "Globe-Trotter," 2-Tube Superhet, Minidyna, "Loop" Receiver, "Doerle" 2-Tube Battery, "Doerle" 3 Tube Battery, "Doerle" 2-Tube A.C., "Doerle" Set of 2 Coils, "Signal Gripper," Duo R.F. 4-tube Receiver, The Sergeant 9-33 Tapped Coil Receiver, Globe-Glider 7, The 2 Tube "Champ"—2 Tubes Equal 2, Ham-Band "2-Tube, Two-Way" Wyeoh All-Way 6, Denton Economy 3, 2-Tube "Regenerative-Oscillo-Dyne" will be found here, with full descriptions. In many cases, we have also included a picture hook-up for those who do not wish to follow the regular symbol hook-up, but wish to have a regular wiring diagram. This is a very handy volume, especially for those "fans" who wish to study the best sets in the short-wave art, from one tube up to ten tubes.

100 Illustrations, 72 Pages, **50c**
Stiff, flexible covers

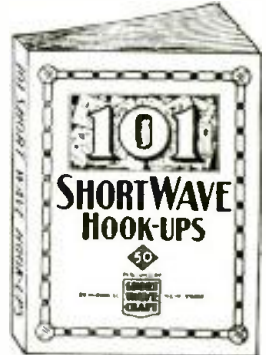

HOW TO BECOME AN AMATEUR RADIO OPERATOR

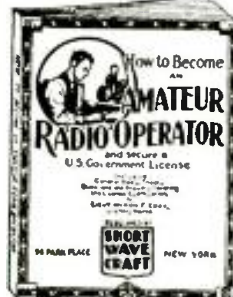

WE chose Lieut. Myron F. Eddy to write this book because his experience in the amateur field has made him prominent in this line. For many years he was instructor of radio telegraphy at the R.C.A. Institute. He is a member of the I.R.E. (Institute of Radio Engineers), etc., the Veteran Wireless Operators' Association.

If you intend to become a licensed radio operator, if you wish to take up phone work eventually—this is the book you must get.

Partial List of Contents

Ways of learning the code. A system of spelling and receiving with necessary drill words is supplied so that you may work with approved methods. Concise authoritative definitions of radio terms, units and laws, brief descriptions of commonly used pieces of radio equipment. The chapter gives the working terminology of the radio operator. Graphic symbols are used to indicate the various parts of radio circuits. General radio theory particularly as it applies to the beginner. The electron theory is briefly given, then waves—their generation, propagation and reception. Fundamental laws of electric circuits, particularly those used in radio are explained next and typical basic circuits are analyzed. Descriptions of modern receivers that are being used with success by amateurs. You are told how to build and operate these sets. Amateur transmitters. Diagrams with specifications are furnished so construction is made easy. Power equipment that may be used with transmitters and receivers, rectifiers, filters, batteries, etc. Regulations that apply to amateur operators. Appendix which contains the international "Q" signals, conversation tables for reference purposes, etc.

50c 150 Illustrations, 72 Pages, Stiff, flexible covers

TEN MOST POPULAR SHORT-WAVE RECEIVERS

—HOW TO MAKE AND WORK THEM

THE editors of SHORT WAVE & TELEVISION have selected ten outstanding short wave receivers and these are described in the new volume. Each receiver is illustrated with a complete layout, pictorial representation photographs of the set complete, hookup and all with while also given. Everything in the simplest language set to a Single T. R. F. receiver is presented. Complete lists of parts are given to make each set complete. You are shown how to operate the receiver to its maximum efficiency.

CONTENTS

The Doerle 2-Tube Receiver That Resolves the 12,500 Mile Mark, by Walter C. Doerle.
2-R.F. Pentode S-W Receiver having two stages of Tuned Radio Frequency, by Clifford E. Denton and H. W. Secor.
The Loza S-W Receiver, by Edward G. Loza.
The Binneweg 2-Tube 12,000 Mile DX Receiver, by A. Binneweg, Jr.
Build a Short-Wave Receiver in your "Brief Case" by Hugo Gernsback and Clifford E. Denton.
The Denton 2-Tube All-Wave Receiver, by Clifford E. Denton.
The Denton "Stand-By," by Clifford E. Denton.
The "Stand-By" Electrified.
A COAT-POCKET Short-Wave Receiver, by Hugo Gernsback and Clifford E. Denton.
The S-W PENTODE-4, by H. G. Cain M.E.
Louis Martin's Idea of A GOOD S-W RECEIVER, by Louis Martin.

75 Illustrations, 40 Pages, **25c**
Stiff, flexible covers

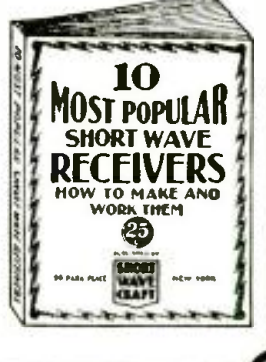

All the books shown on this page are published exclusively by

SHORT WAVE & TELEVISION

99-101 Hudson Street
New York, N. Y.

CLIP-MAIL

OVERSEAS READERS!

These books can be obtained from the following houses:

GREAT BRITAIN

Gorrings',
9a, Green Street, Leicester Square
London, England

FRANCE

Editions Radio
42 Rue Jacob
Paris

AUSTRALIA

McGill's
183-195, 218 Elizabeth St.
Melbourne, C. I.

SHORT WAVE & TELEVISION, 99-101 Hudson Street, New York, N. Y. SWT-4-37

Gentlemen: I enclose herewith my remittance for the amount of \$ for which you are to send me, in duplicate, the books checked below.

- | | |
|---|---|
| () How to Get Best Short-Wave Reception 50c each | () How to Become an Amateur Radio Operator 50c each |
| () 101 Short-Wave Hook-ups 50c each | () Ten Most Popular Short-Wave Receivers. How to Make and Work Them 25c each |
| () How to Build and Operate Short-Wave Receiver 50c each | () The Short Wave Beginner's Book 25c each |

Name
Address
City State

(Send remittance in form of check or money order. If letter contains cash or unused U. S. Postage Stamps, register it.)

Please mention SHORT WAVE & TELEVISION when writing advertisers



Television and the Electron

By Dr. Vladimar K. Zworykin

Director, Electronic Research Laboratory, RCA Manufacturing Company, Inc.

● A few months ago the R.M.A. decided upon a set of standards to be applied to commercial television receivers. Among the requirements specified were those that the system should produce a 441-line picture with a picture frequency equivalent to 30 per second. These standards were accepted by the television engineering world with the utmost complacency.

If such a set of standards had been announced a few years ago it would have been instantly branded as quixotic idealism by almost every worker in the field. When it is realized that television research has been actively carried on for the past quarter of a century, this rapid advance in the last few years takes on real significance.

The cause of this extremely rapid advance which has changed television from a laboratory plaything into a practical engineering accomplishment was primarily a change from mechanical methods of picture transmission and reception to cathode ray systems.

Pioneering work in the field of cathode ray television had been carried on by a few isolated workers for a number of years previous to its general recognition by the major research laboratories. The work of these men served to illustrate to the world that the basis of cathode ray television was sound, and that electronic methods offered a solution to such problems as those of obtaining sufficient illumination on the viewing screen, of inertialess scanning required to obtain high definition, and sufficient sensitivity for the successful transmission of pictures under ordinary conditions of illumination.

Once the way had been pointed out, a number of the more farsighted of the television research laboratories initiated a program of intensive research along this line. This work has been going on for the past five years and has led not only to refining the basic principles advanced by the pioneers but also to the discovery and adaptation of a great number of new principles. As a consequence of this effort, both the television transmitter and receiver have become a practical reality.

The television receiver as it is today—using the *Kinescope**—resembles, in appearance and size, a console radio receiver. The reproduced picture is sufficiently brilliant to watch without strain in a moderately lighted room and is in size about a page of this magazine. Thus, while such a reproducing device is a long way from ideal, it nevertheless is capable of bringing to the observer a picture that has high entertainment value, one which is both pleasing and informative.

The pickup camera employing the *Iconoscope** is but little larger than a commercial 35 mm. moving picture camera, and since it contains no moving parts can easily be made

portable. At its present stage of development its sensitivity is sufficient to enable the transmission of an out-door scene under almost all conditions of lighting, or a studio picture when bright but not uncomfortable lighting is used.

The picture signal from this and accompanying sound pickup is carried to the main ultra-short wave transmitter through cable or radio relay, and from there it is transmitted on a carrier of 5 or 6 meter wavelength. Such a transmitter is capable of servicing a radius of from 30 to 50 miles, depending upon the topography of the terrain.

Of course, it must be recognized that the problems of covering the country with a network of television transmitters, of manufacturing a reasonably priced receiver, and those involved in organizing and producing suitable programs are enormous. These problems are ones that must and will be met by the manufacturer, the production engineer and the technician. This solution is only a matter of time.

Even if some inconceivable law should come into existence that prevented the application of any new principles or developments to the cathode ray television system as it stands today, I am convinced that it would still become a commercial reality, that the system is amply capable of producing a picture which would satisfy a real economic demand.

However, this is equivalent to saying that the automobile of 1910 was a commercial reality. Certainly it was a mode of transportation which met a definite demand, and if all development had ceased at that date the automobile would still be extensively used today. Just as the useful but crude vehicle of 1910 has evolved into the luxurious motor car of today, which in its turn will be supplanted by an even better vehicle in the future, so the application of the laboratory research which is going on today must inevitably lead to improvements in the cathode ray television system.

Of course, the statement that marked advances in cathode ray television can be made is not proof that this progress is possible. However, research which is being carried out in the laboratory gives ample evidence of the improvements that may be expected as our knowledge increases.

To give a concrete example, recent advances in electron optics makes it possible to produce an electron copy of a visible image and secondary emission, which has only just begun to be seriously studied, makes it possible to intensify this copy. These two new principles have been applied to laboratory models of the *Iconoscope* with a consequent many-fold increase in sensitivity. Another example that might be cited is that of the viewing tube. The size of the present television picture is limited because it is viewed directly on the fluorescent screen (Continued on page 759)



(C) Bachrach

Dr. Vladimar K. Zworykin,
Director, Electronic Research, RCA Mfg.
Co., inventor of the important electronic
television devices known as the *Kinescope*
and the *Iconoscope*.

Fourth of a Series of "Guest" Editorials

SHORT WAVE & TELEVISION IS PUBLISHED ON THE 1st OF EVERY MONTH

This is the April, 1937 Issue—Vol. VII, No. 12. The Next Issue Comes Out April 1

SHORT WAVE & TELEVISION, Published monthly at Mount Morris, Ill.

EDITORIAL and EXECUTIVE Offices, 99 Hudson St., New York City

TELEVISION In EUROPE

English and German "Televivers" See Guns in Action—Cooking Lessons—Drama—Styles.



Above—televising an Anti-Aircraft gun in action in London. British televivers had a chance to see this gun crew in action during a mock night attack on Alexandra Palace. Television camera at T; microphone for picking up sound is suspended on the boom at the left. Below—A close-up of the mast and transmitting aerials for both the voice and image frequencies at Alexandra Palace, London.

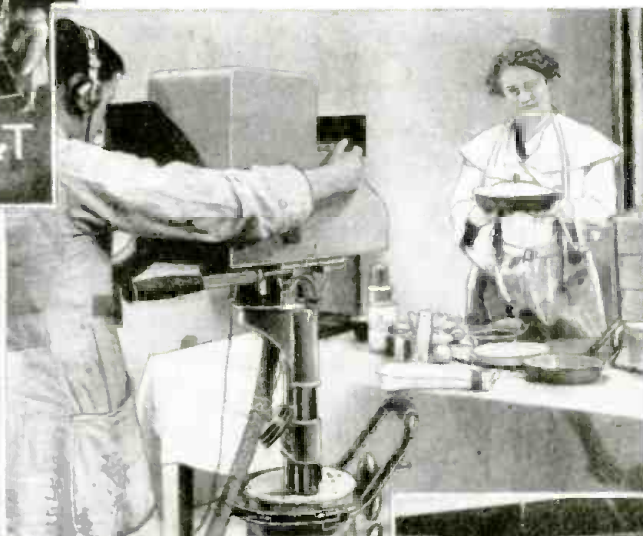

Left—Televising a cook in action for London television audiences. The lady holding the pie in front of the pick-up camera is Moira Meighn. Instruction in cooking will undoubtedly be very popular with television audiences everywhere, as the exact method of mixing the ingredients used in certain recipes will be clearly shown.

The two photos below show the famous television inventor, John Logie Baird. These pictures were taken in an English theatre where Mr. Baird's new system of projecting large television images were demonstrated. The images were shown on a screen measuring 8 feet wide, by 6 ft. 6 in. high. The center photo shows Mr. Baird in the television projector room. Photo below shows him in front of pick-up scanner. See page 182 for diagram.

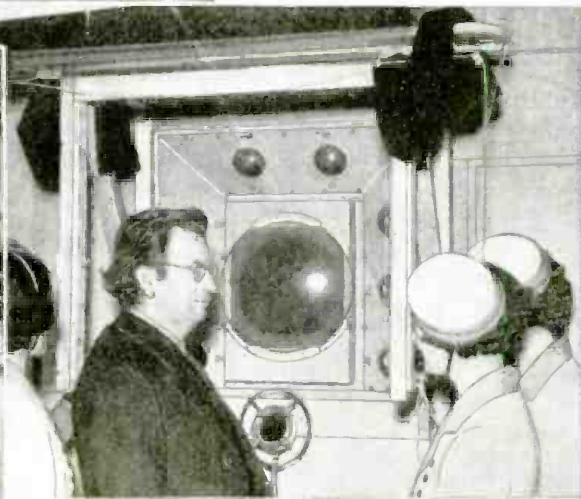

Television in Germany—Photo below shows the newest model of German "direct pick-up" television camera. The camera is made of aluminum to reduce its weight to the minimum, and inside the aluminum box we find a German model of the iconoscope developed by Dr. Zworykin of RCA. This particular instrument as developed by the Telefunken Company, possesses an improved color sensitivity. The definition is 360 lines.



A television image as reproduced with 180 lines and 25 frames per second, in Berlin, by means of the new Telefunken television receiver. This apparatus uses a cathode ray tube and reproduces the images in a color combination which appears to be black and white. Technically their actual color is however, a yellowish black. Camera "fans" will be interested in knowing that the photo at the right was taken in 1/25th of a second.



Above: A television studio in Berlin—Many new discoveries are being made with regard to the most suitable colors to use in making up television actors. Many strange colors are used in making up the face for television, owing to the peculiar color response characteristics of the photo cells used in picking up the image. Such colors as dark brown shades for lips, orange shaded powders for cheeks and greenish shades for rouge.

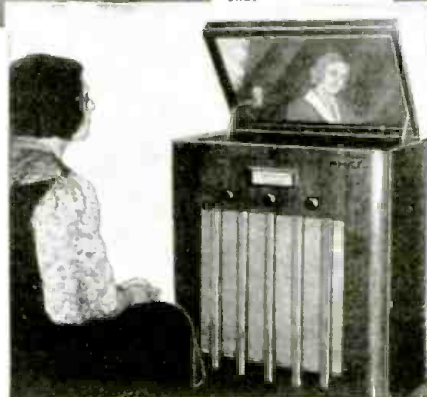

A television enthusiast viewing the image on one of the latest model Telefunken receivers. Three knobs only are used on the front of the set for tuning in voice and image. The cathode ray tube is mounted vertically, the image appearing on a metal mirror fitted on the lid of the cabinet. The center knob tunes the image and sound; right—sound volume control; left—image control.



Taking the code test in the F.C.C. examination room in New York City. Note particularly that single earphones are used.

● Here are some frequently-asked questions about the amateur radio license, with the correct answers:

Q. How old do you have to be to get a license?

A. Only old enough to read and write. There is no limitation whatsoever as to age, or to sex for that matter. There are plenty of girl and women operators.

Q. How much does the license cost?

A. Not a cent.

Q. Can you ask for certain call letters? For instance, your initials?

A. No. It's a waste of time even to ask. You just take what you get.

Q. How long do the licenses run?

A. All amateur licenses are now good for three years.

"HAM" LICENSE TEST EASY—

Says Robert Hertzberg

Who Took the Examination

● A GOOD MANY would-be radio amateurs fail to obtain their licenses merely because they are nervous or apprehensive when they take the government examination in an office of the Federal Communications Commission.



This motor-keyed audio oscillator, operated here by Charles T. Manning of the F.C.C. staff in New York, is accurately adjusted for 13 words per minute for the "code test" for amateur license applicants.

They may have "boned up" on the technical questions and practiced the code diligently for months in advance, but they apparently lose their self-confidence when they enter a room with several dozen other applicants and find themselves in unfamiliar surroundings.

There would be fewer failures for this reason if embryo "hams" realized in advance how simple the procedure is. Let us visit the large and busy office of the F.C.C. at 641 Washington Street, in New York City, and see if we can't get some valuable pointers.

The applicant's first step is to fill out Form 610, a four-page sheet entitled "Application for Amateur Operator and/or Station License." This merely calls for statistical information. The really important questions which must be answered satisfactorily are 7, 8 and 9, which deal with the citizenship of the applicant. If you are not a citizen of the United States you simply cannot become a licensed radio amateur.

The applicant is required to swear to the truth of the statements he makes on Form 610 and to execute the *oath of secrecy*. Then he goes into the main examination room, which is furnished with a row (Continued on page 765)



Charles Mencher (left) of the F.C.C. staff in New York, giving the oath of secrecy to an applicant for an amateur license.

AMATEUR RADIO AND THE FLOOD

● HAM radio stations have again distinguished themselves by carrying on a tremendous amount of important traffic throughout the flood area. Among other things the Federal Communications Commission ordered the 75-meter phone band cleared of all traffic so that designated stations could proceed to transmit important messages. According to the press, the A.R.R.L. maintained a continuous watch on this channel to see that it was kept clear for important traffic.

The NBC mobile transmitting and receiving unit distinguished itself by serving as an emergency police unit. When the radio facilities of the police department of one of the larger cities in the flood area was put out of commission by the rising waters, the mobile unit bridged the gap in fine shape, thanks to the very elaborate short-wave transmit-

ting and receiving equipment aboard.

At the request of harrassed amateur radio operators struggling to maintain disrupted communication services in the flooded Ohio and Mississippi River valleys, the Federal Communications Commission at once intervened to restrict all amateur operation in certain bands to flood relief traffic.

The order, inspired by congestion on the crowded amateur frequencies which often blotted out the weak signals from emergency stations, frequently operating with battery power under the most adverse conditions, banned all communications not directly involving emergency messages from the amateur 3500-4000 kilocycle and 1715-2000 kilocycle bands.

Although wire services, both telegraph and telephone, have been maintained in the larger cities through heroic efforts by the public utilities companies,

numerous smaller towns are completely without communication of any sort except that provided by the volunteer amateur operators. These operators, working with networks organized by the Army, Navy, Coast Guard and the American Radio Relay League's Emergency Corps, have been severely handicapped by interference caused by the large number of stations working in the limited territory available.

The text of the Commission's order, circulated by the official broadcasting network of the American Radio Relay League, follows:

To All Amateur Licensees:

The Federal Communications Commission has been advised that the only contact with many flooded areas is by amateur radio, and since it is of vital importance that communication with flooded areas be (Continued on page 758)



President Thanks HAMS for Flood Work

• • •

Short Waves Cover Inauguration

When members of the Washington Radio Club called at the White House to present inaugural congratulatory messages from governors of 39 states and territories, sent to the President via "amateur radio," the Chief Executive took occasion to heartily thank them and their fellow "hams" for the vallant service they had rendered in maintaining communication with the flood-stricken areas. Left to right, James L. Holmes, W3GKW; Miss Elizabeth Zandonini, W3CDQ, of the U. S. Bureau of Standards; C. M. Godfrey, W3CYO; Eppa Darne, W3BWT, of the Army amateur network; Lieut. J. H. Nicholson, N3EE, of the Navy network; R. E. Macomber, W3CZE, and Roy C. Corderman, W3ZD, of the A. T. & T. Co., who presented the messages to The President.



Portable short-wave transmitters and receivers mounted on motorboats and aboard trucks, so that they could move about quickly, proved extremely valuable during the flood. Above—one of the mobile units in operation at Memphis, Tennessee. This station kept in touch with the stricken areas and served as a guide for relief workers. Robert Kelly of New Orleans, La., is seen operating, while John Willmot of Mobile, Ala., looks on.



Radio Amateurs certainly covered themselves with glory again during the flood. Here we see a short-wave transceiver being operated by an amateur, while a fair refugee "listens in." The batteries for operating the transceiver are in the box at the right of the photo; the antenna used is a telescopic affair which can be opened up like a fish-pole. This particular short-wave "set-up" in action was snapped by our photographer at Portsmouth, Ohio.

Below—One of the CBS Radio Cars used in picking up "spot news" at the inauguration in Washington, D.C. Note the special antenna mast mounted on the rear bumper, as well as the telescopic antenna.



Left—This "shot" shows the special CBS master control booth located just beneath the inaugural stand on the capitol steps. Paul White and Henry Grossman of CBS are seen directing the activities of 18 announcers, 20 engineers, and a "raft" of mobile stations.

Right—NBC covered the inauguration with a whole battery of announcers, and engineers; one of their portable short-wave transmitters, carried on the back of the announcer, is shown in this picture taken during tests.



TELEVISION COURSE

"Electronic Television"

Lesson 3

By George H. Eckhardt,

Author, "Electronic Television"



← ● Photo at left shows, in enlarged portion, how half-tone image is composed of dots of various sizes, similar to television image structure.

● → Right—the Iconoscope, the special vacuum tube which forms the heart of the RCA television system. Note deflecting coils at right of photo.

● Below—for the first time a drawing is here presented showing the construction of the Philco television camera tube. The image is picked up by a lens and flashed on to the signal plate of the tube.

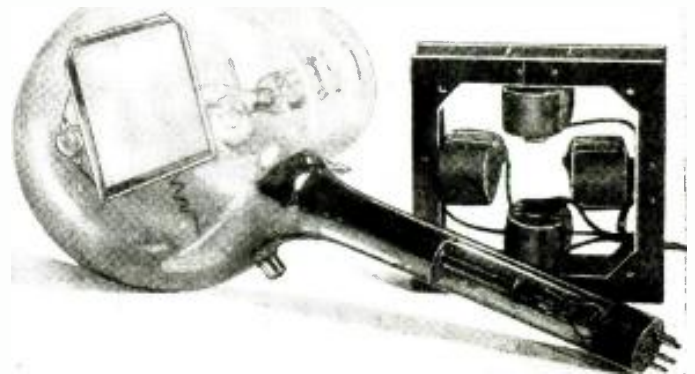

● IN reading this page will be found a good example of the basic principle of SCANNING. Each line is read from left to right, then the eye quickly goes back to the left again, and follows slowly the following line from left to right. Printed text is already broken up into consecutive lines.

And again the printed illustrations in this magazine give a good example of another basic principle of television. In the half-tone reproductions each picture is broken up into a number of elements, or dots, of varying intensity of light and shade, and the result is a reproduction of the picture. The greater the number of dots, or elements, per square inch, the better the picture reproduction.

The Standard proposed for electronic television in the United States is 441 lines of definition per complete picture frame.

The Standard Aspect Ratio, the height to the breadth, is three to four. This has been set simply because this ratio gives a pleasing picture.

Now in looking at Fig. 1, it will be seen that if there are 441 lines as shown, then there must be 586 divisions across the top of the picture, in order to divide it into squares. (441 is to "x" as 3 is to 4.)

This will mean that each picture frame is divided into 258,426 squares. The signal denoting the degree of light

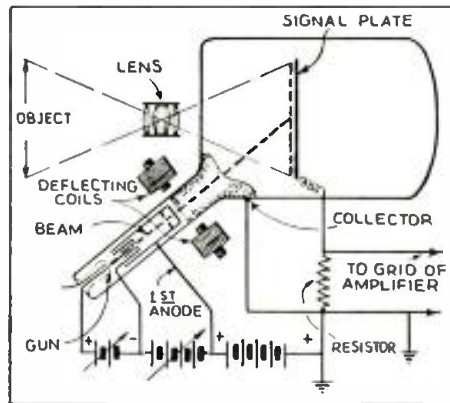

or shade of each of these squares must be picked up in the television camera, amplified, and reassembled at the receiver, thirty times per second!

Interlaced scanning will be used, and this means that each picture will be scanned twice, each time with half the number of lines. Thus each complete frame will be scanned 60 times a second, using a half picture, or 220½ lines each time. The result is of course the same as 441 lines thirty times a second. The

lines of the second half-picture fall between the lines of the first half-picture.

Now again looking at Figure 1. Each element varies through all of the shades, from complete white to complete black. Assume that the elements across the top line, from left to right, were alternately completely black and completely white.

It is necessary to transmit the signal denoting the shade of each element from the pick-up to the receiver. If an element of the picture at the pick-up is completely black, then to reproduce this at the receiver, the cathode ray must be extinguished for that element; and if an element at the pick-up is completely white, then the cathode ray at the receiver should be its brightest. From A to B is one complete cycle. In this cycle it will be seen that from A to C the ray would be extinguished at the receiver to give a black element, and from C to B it would be brightest to give a white element. Thus it will be seen that the number of cycles required for each picture frame is one-half the number of elements, or about 120,000 cycles for each complete picture frame.

But each complete picture frame is scanned thirty (Continued on page 771)

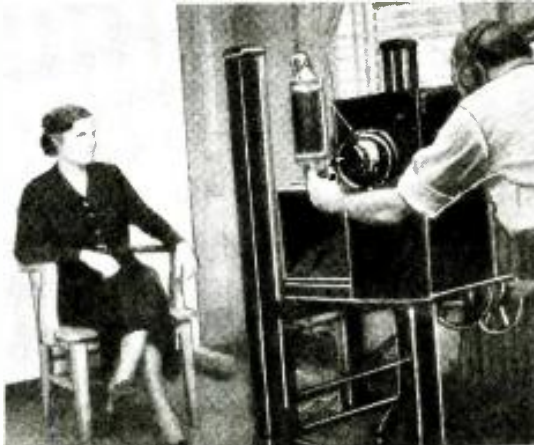

● Left-hand photo shows expert making a television tube in the Philco Laboratory.

● Center — A view of the Philco television studio. The image is focused in a similar manner to that used with a camera

● Right — Several Philco Television engineers with a Philco camera. Left to right, A. F. Murray, F. J. Bingley, P. J. Konkle.

S-W's AID MOVIE DIRECTORS

FRONT COVER FEATURE

Movie directors have found short-wave phone sets very useful for inter-communication in taking big scenes spread over large areas.

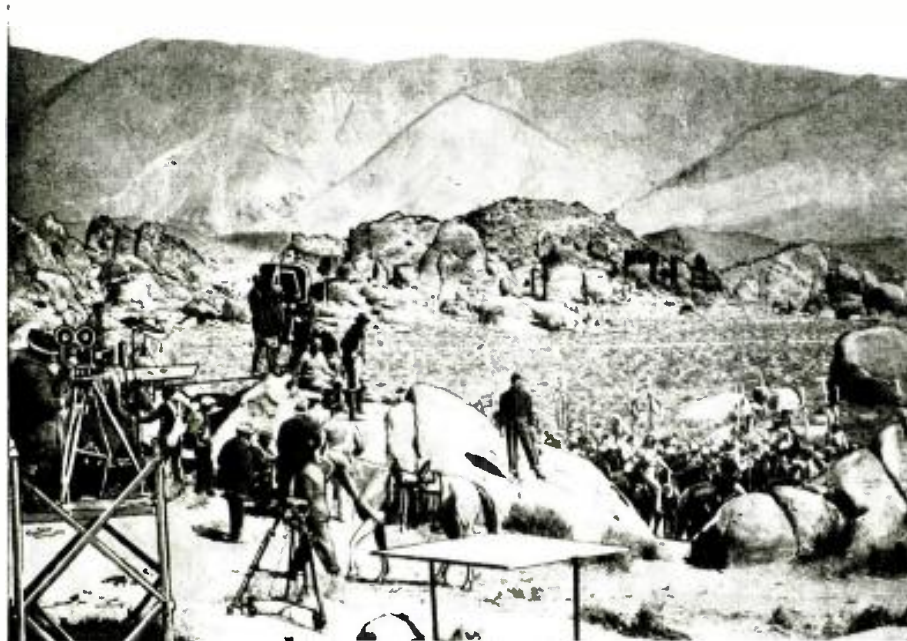

perative. Short-wave transceivers, or in some cases separate transmitters and receivers, have frequently been used, even as long as 10 years ago, in Hollywood for just this purpose.

Before the days of light-weight portable short-wave sets, capable of talking several miles and which can, if necessary, be carried as a pack set on a man's back so that he can walk about while dispatching orders or receiving them, telephone wires were frequently strewn across the field. But in such a picture as *The Charge of the Light Brigade*, where hundreds of mounted men are charging toward the camera stands and passing beyond them during the action, telephone wires are frequently disrupted.

Short-wave phone sets which are self-contained, with (Continued on page 766)

← Left—Scene taken "on location" during filming *The Charge of the Light Brigade*. Short-wave "phone" can be of inestimable value in linking camera units and assistant directors about the lot with the chief director.

● IN photographing such gigantic spectacles as *The Charge of the Light Brigade*, which was filmed by Warner Brothers, some means of instant communication between the chief director and his assistants located at spots about the movie lot is practically im-



The diagram above shows the great value of short-wave "phone" sets in directing a big movie scene, such as that shown on our front cover and taken from *The Charge of the Light Brigade*. Not only are the various "camera groups" kept in constant touch with the director-in-chief by short-wave phone, but his aids stationed at various points about the movie lot can be given orders to diminish or increase smoke effects, etc.



The photo herewith shows one of the thrilling scenes from *The Charge of the Light Brigade*. Short-wave "phone" sets are a wonderful help in establishing instant communication between the director and his assistants, particularly when they are scattered over such a great area as occurs when taking such a battle scene as this.

PCJ, Eindhoven, Has Novel Voice Recorder



The photo shows the two-unit recorder of short wave station PCJ, Eindhoven, Holland, which operates with an interesting method of recording and reproduction.

● THE photos show one of the recording units of the Philips-Miller system, as used in Holland for an entirely new type of sound recording. We see at the right the celluloid ribbon, coated with an opaque layer. The ribbon

passes through the cutter-head, right-side center and is led at once through the photo-electric pick-up (left side, box in front) to make instantaneous check-ups possible, and finally is reeled on the storage reel at the left.

This apparatus has not only the advantage that all recordings may be checked up during

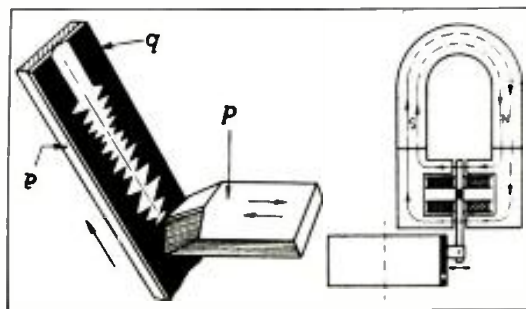

Above—PCJ's unusual sound-recording system with amplifier, etc. Left—Flat Knife Cutter which records sound tracks of varying width into moving ribbon.

the recording and that no developing, etc., is required, but it also has the advantage that the "engraved" sound recordings are less noisy than photographically reproduced ones, and, last but not least, the opaque coat- (Continued on page 774)



Low-Cost Oscilloscope—

Part II—By Howard G. McEntee, W2FHP

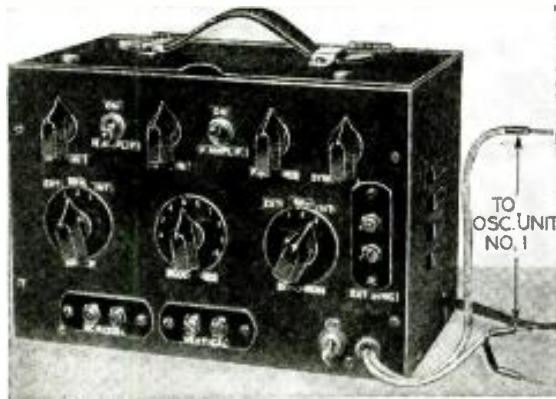

How to build a "companion unit" to use with the Oscilloscope described in the last issue, which used a 913 cathode ray tube.

case if the original instrument was rebuilt, we have designed a companion unit to work in conjunction with the original, the two units together being as versatile as the expensive commercial oscilloscopes and being able to do all the large ones can. In addition, this second unit may be used in conjunction with any of the so-called basic oscilloscopes, that is, those having no sweep circuits or amplifiers, just as our first unit had none.

Besides this it may be used as a straight high-gain two-channel amplifier, as may be required for pre-amplifier use, although this may require the addition of large cathode by-pass condensers on the 6J7 tube. In a pinch, the unit can be used as a source of audio tone, although the note from the sawtooth oscillator is rather harsh.

The equipment is contained in a case of the same size as the oscilloscope proper, and connections are made to the latter through a 3 wire cable, the shield serving as the third wire. Since both units have (Continued on page 762)

Wouldn't you like to own a good cathode-ray oscilloscope? The present article tells how you can build a complete companion unit for the home-made oscilloscope described in the last issue. The two units permit all sorts of measurements to be made.

At right—diagram of the auxiliary oscilloscope unit here described by Mr. McEntee.

● THOSE who built the baby oscilloscope described in last month's issue will probably by now be ready to use something a little more advanced, and with which more complete measurements may be made.

In order to make it unnecessary to discard any parts, which would be the

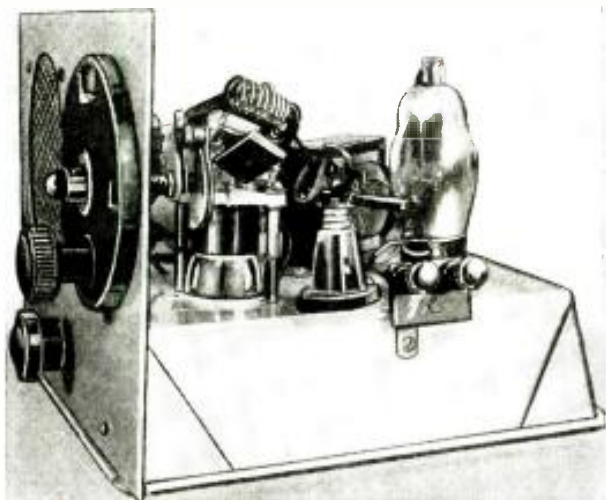
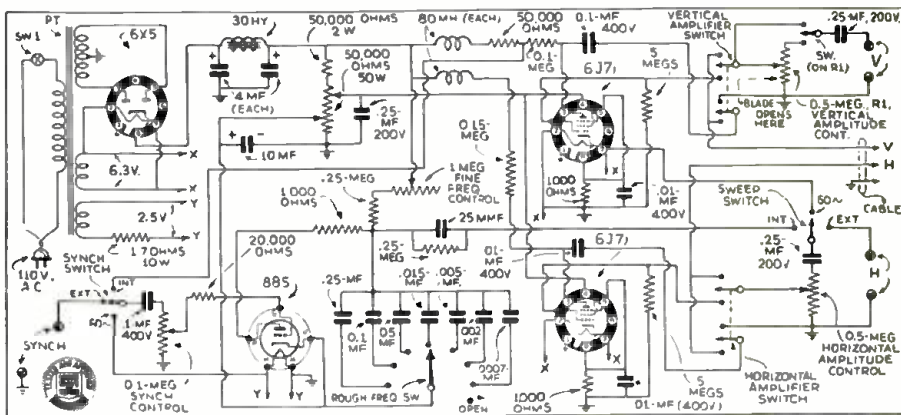

A bread-pan serves as a chassis for this 5-meter A.C.-D.C. Receiver. It works a loud-speaker, yes sir!

● HERE is a five meter receiver for the Ham or SWL who wishes to look into the possibilities of the 56 megacycle band at little expense, but who wants a receiver capable of giving reasonably satisfactory performance. The circuit is not new. It is the now well known "Minute Man," famous for its sensitivity and selectivity. Its adaptation to a two tube A.C.-D.C. circuit is new. It has been in use here at W3GHQ for several months.

The use of the popular 12A7 permits reasonable volume on the tiny speaker. On some signals it can be heard all over a medium-sized apartment—much to the disgust of the ex-YL. The set is very simple to construct. The hum level on AC is quite low. In fact it is not audible when the set is in regeneration, or on a signal.

A 5-Meter A.C.-D.C. Receiver

By
Jack Barnette,
W3GHQ

The panel is 7 x 12 inches or made to fit your particular chassis. The chassis may be almost anything you have handy. The set shown is built on a tin bread-pan from the 5 and 10.

The 37 tube is mounted in an inverted position to permit the shortest possible leads to grid and plate. The coil should be soldered directly to the plate prong contact on the isolantite socket, as should one lug of the tuning condenser. The other end of the coil—and the other tuning condenser connection—should be soldered to one lug of the tiny variable grid condenser. This in turn has the remaining lug soldered to the socket grid contact. The 10 megohm grid-leak is connected (Continued on page 773)

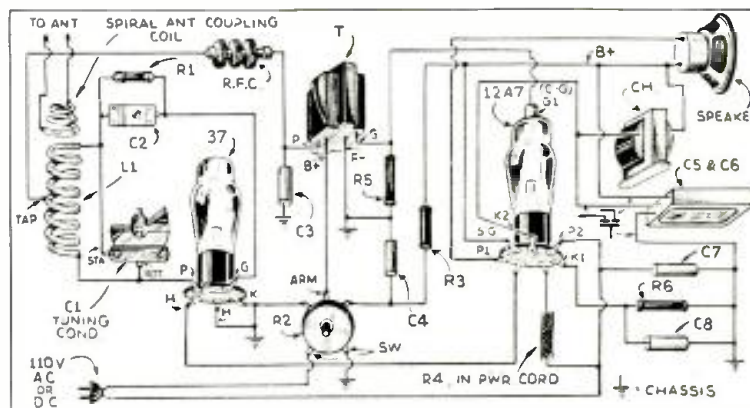

Simple to build? We'll say so! Look at the diagram—and it furnishes its own plate supply current too!

SHORT-WAVE BEGINNER

A One-Tube as Regenerative

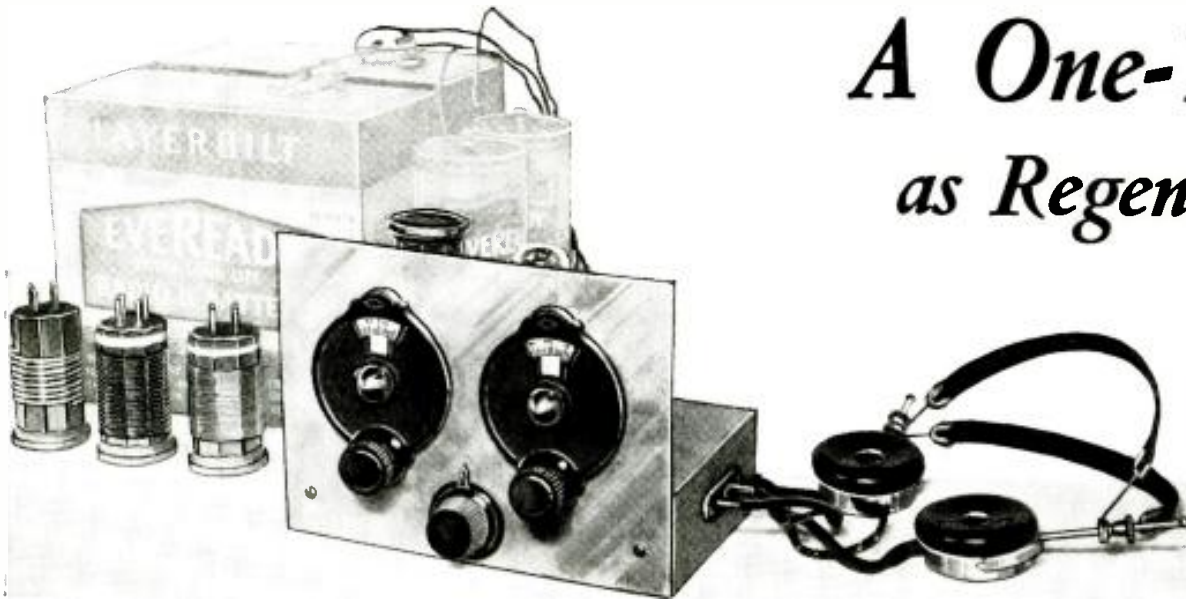

The 1-tube receiver around which this first beginner's article is written. This set really "pulls them in!"

● THIS is the first of the series of articles devoted especially to the *Short-Wave Beginner*. We will endeavor to point out in clear language the most prominent factors in successfully getting started in short-wave radio.

His first and greatest problem is of course, choosing the receiver with which to start. Many beginners will, or have purchased their receivers ready-made, while many others will construct their own, for we all admit there is a certain satisfaction in obtaining results with a set constructed with one's own hands. The beginner who has purchased his receiver will find many valuable hints in this series of articles, and we believe that he should follow them

as closely as the man who wishes to construct his own.

We have chosen the famous "19 Twin-Plex" with a few modifications, as the first example in the line of amateur construction. This receiver is extremely simple to construct, and at the same time produces excellent results. The "19" tube, as our tube chart tells us, is a *twin-triode*; that is, two, *three-element* tubes are contained within a single glass envelope. In the receiver to be described, one set of elements in this tube acts as a *regenerative detector*, and the other set of elements as a stage of *audio amplification*. We have presented both schematic and physical diagrams of the receiver in order that there will be no

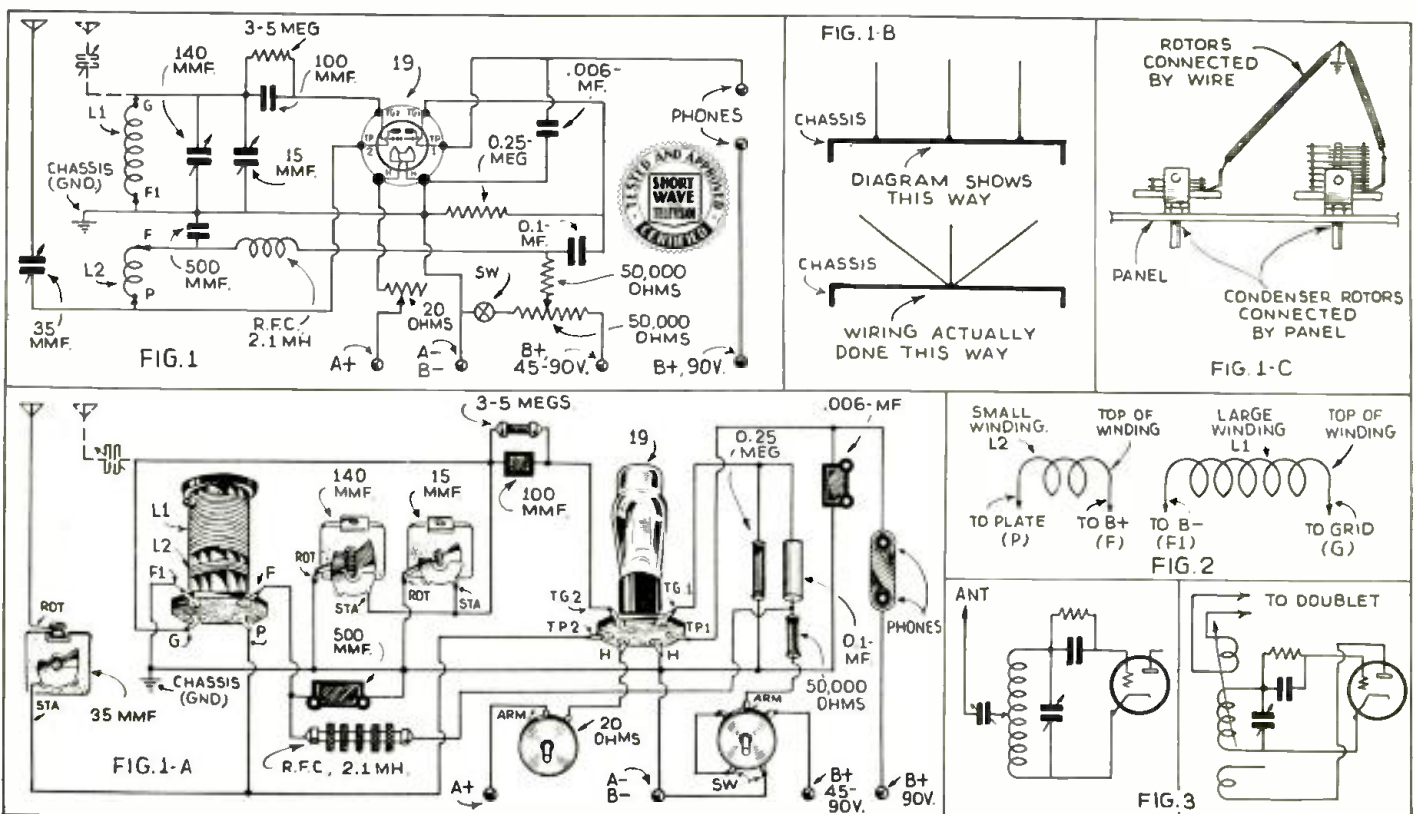

Both physical and schematic diagrams of the 1-tube beginner's receiver.

By
George W. Shuart,
W2AMN

● The department started with this first article is to be devoted entirely to the "beginner." The receiver described is a modification of the famous "19 Twin-Plex" and it was chosen as the first attempt in the line of construction. Complete details for building this receiver are given in the article, together with much other valuable information on subjects which have frequently been a source of trouble to the beginner. Also read the box below, wherein your chance to win a \$25.00 prize for the best "log" obtained with a duplicate of this set, is fully explained.



Receiver Using Dual 19 Detector and Audio Amplifier

danger of the beginner not being able to follow the diagram.

What Diagrams Show

One word about diagrams: Diagrams merely serve to indicate what terminals are connected together, and this may be done in several ways, usually in diagrams such as ours, the connections are drawn in a manner most convenient to the draftsman and also to lend symmetry to the diagram, enabling it to be clearly read. Where two or three terminals are connected together along a single line, the proper procedure is to make the leads as *short* and *direct* as possible. For instance, the draftsman may have carried one lead over three or four other leads and through a certain course in the diagram. Of course, this should *not* be done in the construction of the receiver. The leads should be run directly to the points concerned. In figure 1, we have endeavored to show what we mean by running the wires in a *direct fashion* rather than as the usual diagram indicates. In many cases, and particularly with this receiver, the chassis and panel is made of metal and serves as the low potential or grounded portion of the circuit.

For instance, the *rotors* of the two tuning condensers are *not* insulated from the chassis, and therefore are connected together electrically through the metal panel. However we recommend that a *separate connection* be made with hook-up wire. The condensers do not have to be insulated from the panel, but they should be treated as though they were, and the necessary connections indicated in the diagram should be carried out with hook-up wires.

The reason this is done is to eliminate the use of the panel as the sole connecting agent for the simple reason that there may be radio frequency currents flowing in the panel, due to its serving as an electrical connection, and therefore when the operator's hand or body comes near, or in contact with the panel, a serious *de-tuning* effect will be noticed, just the same as though the operator's hand were brought in close proximity to the coil, although perhaps not so pronounced. So much for diagrams.

Follow Values of Parts Specified

The values of the various parts indicated in the diagram

\$25.00 Prize for Best "Log" Obtained With This 1-Tube Set

● The editors are offering a \$25.00 cash prize for the best "Log" of short-wave stations heard with this 1-tube receiver. The closing date for entries in this contest is May 25th, and the announcement of the award of the winner's name will be given in the August number, which comes on the newsstand July 1.

RULES

1—Verification cards must be submitted for each station heard, and all veris must be foreign. The stations to be verified and entered in this contest are short-wave broadcast stations only, no amateur or commercial code stations. The cards must specifically verify the exact date of reception.

2—The listener must build this 1-tube set himself, and send a clear photograph.

3—A notarized affidavit must be submitted with the entry, testifying that the entrant was the sole participant and heard the stations listed on a duplicate of this 1-tube receiver, which he built himself.

4—The cards must be submitted in order, to conform with the itemized list submitted, so as to simplify checking by the judges.

5—In a case of a tie, duplicate prizes will be awarded.

should be followed exactly if proper results are to be obtained. Slight deviation from the values shown is possible in many cases without serious effect, but it is not recommended that the beginner make these changes until he is thoroughly familiar with the particular values which are not critical.

The *power-supply* for this receiver consists of two 45 volt "B" batteries, and two 1½-volt dry cells. The 19 tube requires two volts for the filament, therefore it is necessary to use a rheostat in order to reduce the voltage supplied by the three-volt battery unit. No voltmeter is required for measuring the voltage applied to the tube if the operator always remembers to operate the filament with the lowest voltage consistent with good reception. In the schematic diagram, figure 1, we have shown alternate methods of connecting the antenna to the receiver. The *solid* connections shown connect the antenna to the plate side of (Continued on page 767)

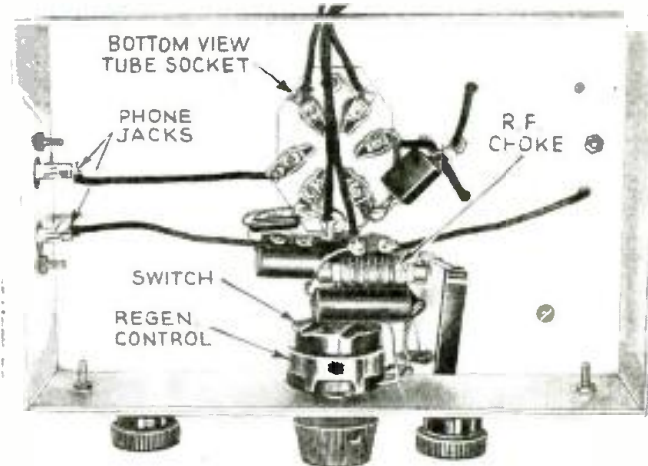
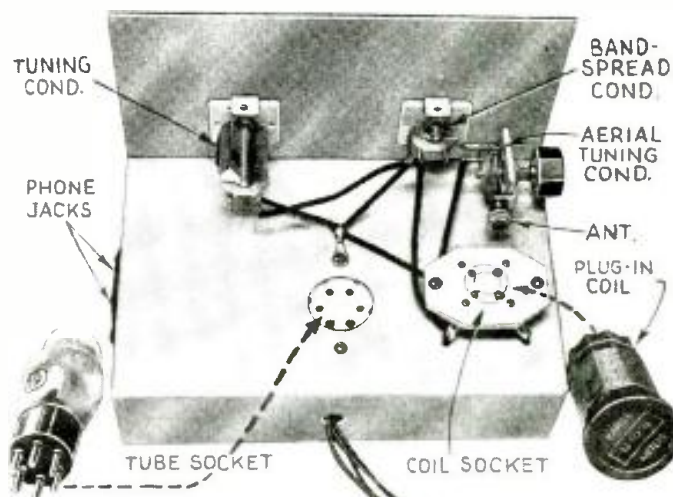

Rear and bottom views, showing the various parts and their respective positions.

1937 Senior SPACE-EXPLORER

By H. G. Cisin, M. E.

This 5-tube receiver uses plug-in coils to cover the bands from 17 to 560 meters. It uses a regenerative circuit, which makes it much simpler for the beginner to build than the superhet type of circuit. Maximum results for the number of tubes used are assured.

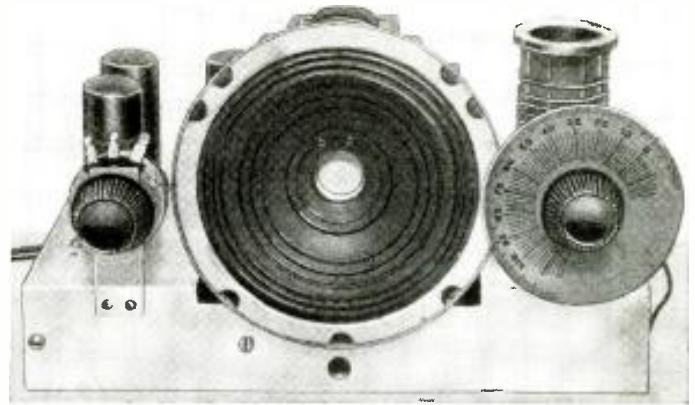

Front view of the Sr. Space-Explorer; it works on 110 Volts, A.C. or D.C.

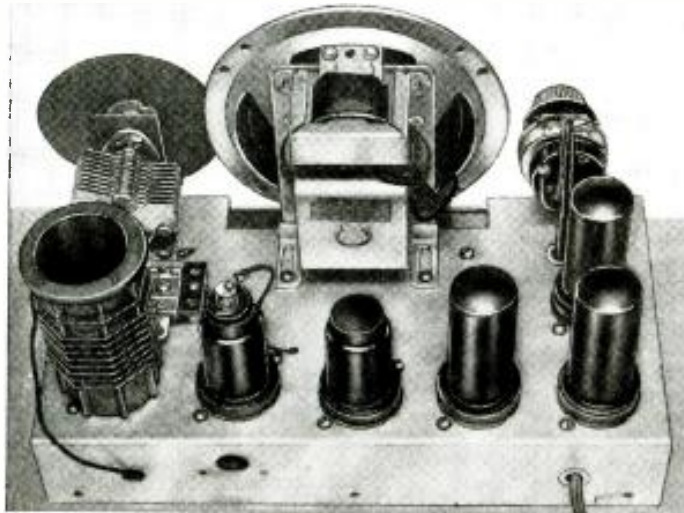

Rear view of the 5-tube receiver, which has its own plate-supply built in.

volume and tone quality using a standard dynamic speaker. This set was designed especially to meet the requirements of the advanced novice.

In addition to the simple regenerative detector, there are two resistance coupled audio stages. Further simplification is attained through the use of the A.C.-D.C. circuit, which eliminates the power transformer.

Metal Tubes Employed

Metal tubes are used throughout this receiver. The triple grid 6J7 is employed as a regenerative detector. The 6C5, a triode, is used in that first audio stage, while the 25A6, a power amplifier pentode is the output tube. For A.C.-D.C. service, this latter tube has a power output of .9 watt. The rectifier tube is a 25Z6, used as a half-wave rectifier.

The K-5-A ballast tube employed is a worth while innovation, undoubtedly destined to supersede resistance-type line cords. This new ballast tube serves several useful functions. First of all, it reduces line voltage to the correct value for heating the tube filaments. In addition, it prevents line surges from affecting the other tubes, thus protecting them and increasing their useful life. It also acts as a fuse in case of a short-circuit and since it can be replaced without fuss or soldering, this convenient feature alone, gives it a big advantage over the old-style resistor line cord.

5 Plug-in Coils Cover 17 to 560 Meters

Five plug-in Hammarlund coils are used to cover the band from 17 to 560 meters. These are tuned by a .00014 mf. variable condenser. By connecting a 15 mmf. variable condenser in parallel with the tuning condenser, as shown on the diagram in dotted lines, it is possible to obtain *band-spreading*.

Those who wish to add an extra tube to this set can do so by using two 25A6 tubes in push-pull in the output stage. In this case, of course, a push-pull input transformer will be needed in place of the resistance-coupled stage and the dynamic

(Continued on page 764)

● IN describing the construction of various radio receivers the writer has carefully kept in mind the desirability of producing a series of articles, progressively graded so as to permit the novice to augment his radio knowledge with each successive set he constructs.

The December, 1936, issue of *Short Wave Craft* carried an article by the writer explaining how to construct the Junior Space-Explorer. This receiver employed a combination of metal and glass tubes in a simplified regenerative circuit, producing power sufficient to energize a small magnetic speaker.

The Senior Space-Explorer, with only slight added expense for parts, is a more powerful receiver, capable of excellent

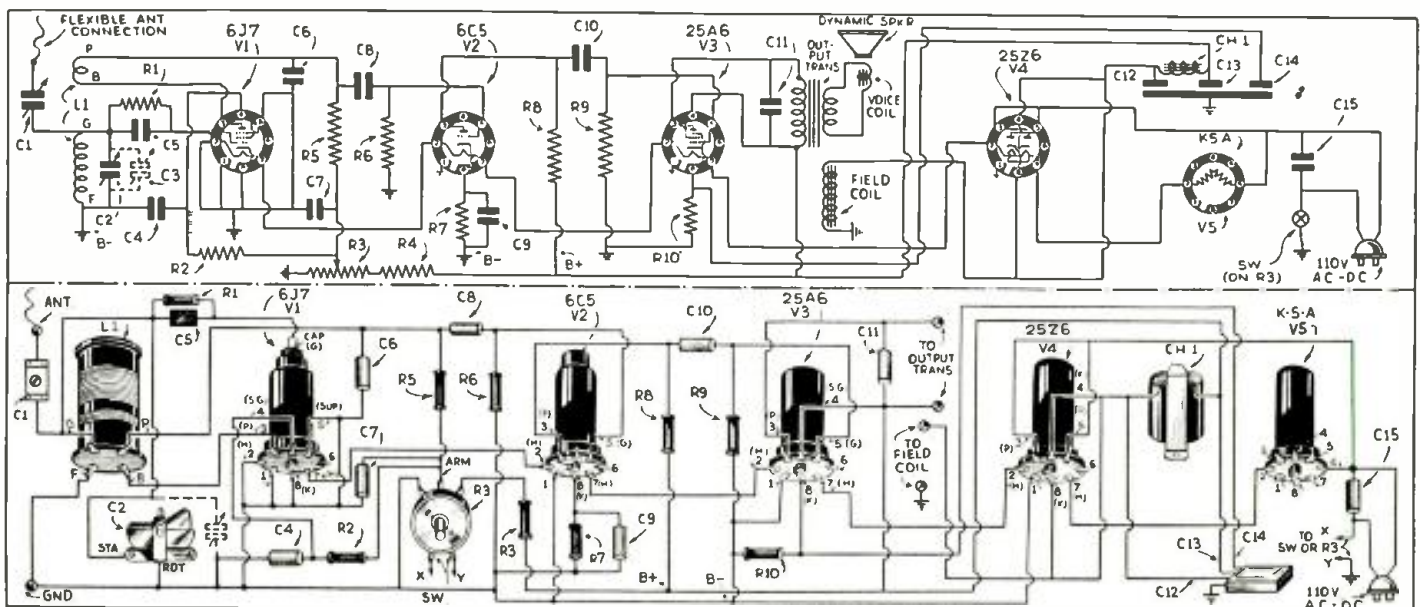

Wiring diagram of the Sr. Space-Explorer which employs a regenerative detector circuit. The new Ballast tube is used to reduce the 110 volt potential to a suitable value for the tube heater circuit.

Is YOUR Receiver Top-Notch?

Make It "De Luxe" by Adding

By Clifford E. Denton

NOISE-SILENCER and BEAT-OSCILLATOR

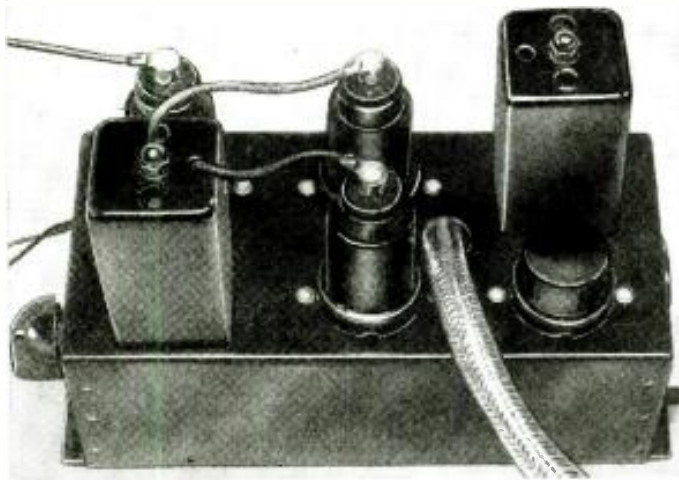

Neat appearance, plus sterling performance, mark this Noise-Silencer. It can be used with "any" Super-Het.

● EVERY short-wave "fan" has a pet set. But every fan does not want to take the set apart to incorporate improvements. Many of the keenest listeners have a desire to add units or circuits, but have factory-built receivers that cost plenty of money and hesitate to make changes. Here is a simple way to incorporate worth-while changes, without taking your present set apart or the necessity of radical alterations, and one that will appeal to the experimenter and the listener-in as well.

Noise-Silencer for Any Set

First, here is a *Noise-Silencer* Unit that will work with *any* set, even though the set has but *one* I.F. stage. Most of the silencer units developed could not be used with receivers having one I.F. stage, due to the losses introduced by the silencer unit. A study of the diagram, Fig. 1, shows that an additional I.F. stage is incorporated in the silencer unit to compensate for the normal loss which is to be expected. In fact the use of the silencer unit with receivers having one I.F. stage will result in slightly greater sensitivity when the threshold control is in the minimum position.

It will be remembered that silencers of this type are the only units that permit operation in sections that are known to have high noise-levels caused by man-made interference, such as vacuum cleaners, oil burners, battery chargers, etc.

This *silencer* will operate with any type of superheterodyne receiver, regardless of the number of I.F. stages and has enough "gain" in the built-in I.F. stage to compensate for any losses. It supplies its own power for the tube heaters and draws a very small amount of current from the plate supply of the receiver.

So, if you want freedom from man-made interference add a silencer unit and the next time you show off your

Complete constructional details are given for building and using very latest model Noise-Silencer and Beat-Oscillator.

S.W. set, give your friends *more signal and less noise!* you will like it and they will be amazed. That's *Deluxe No. 1.*

Adding a Beat-Note Oscillator

Deluxe Item No. 2 is a *Beat-Note Oscillator*. This handy unit should be incorporated in every short-wave and all-wave receiver. Many cus-

tom-built sets feature a built-in oscillator, but there are hundreds of all-wave receiver owners with factory-built jobs that need the advantages of the beat note to simplify tuning. Especially those sets having a low tuning ratio on the tuning dial. Fast dial speeds tend to make the listener-in pass over many stations that would otherwise prove to be good "catches."

A study of the circuit diagram Fig. 2 shows that the unit has its own built-in power supply. Thus, does not throw an additional load on the receiver with which it is used. No unbalancing or change in the tuning or I.F. transformers of the radio set is necessary at the time of installation, which is a point well worth mentioning.

The output of the oscillator is readily controlled by means of potentiometer R3, and the effect of the loading of the tube on the tuned circuits of the receiver can be compensated for by means of the midget variable coupling condenser C1. These two components simplify the preliminary adjustments made at the time of installation.

Three models of the Beat Frequency Oscillator can be built. A.C.-D.C. using a 6C5 oscillator and a 25Z6 rectifier as shown in Fig. 2; A.C. operated by using the small power transformer specified, and using a type 76 tube as the oscillator and an 80 as the rectifier. A battery model can be made at still lower cost by using a single type 30 as the oscillator tube. In that case the power-supply for the unit can be taken from the receiver.

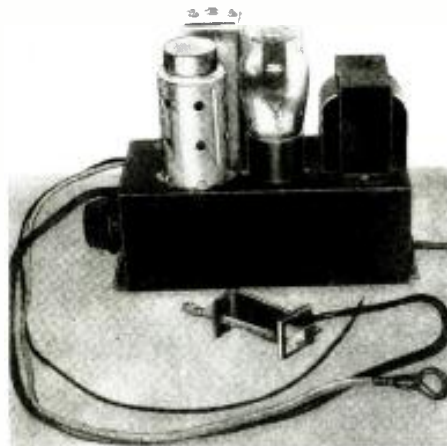

You can easily build this Beat-Oscillator. It helps you find weak stations.

Construction and Wiring

The construc- (Continued on page 768)

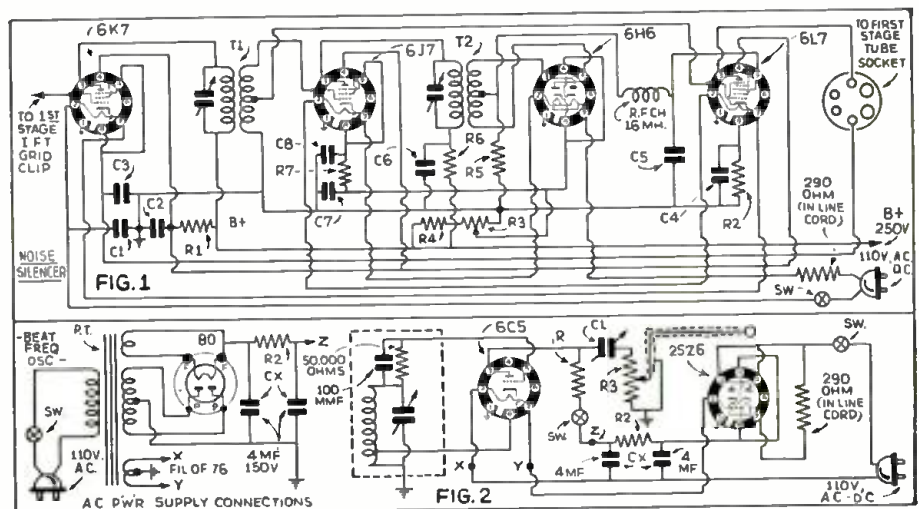

Diagrams of Noise-Silencer and Beat-Oscillator. (No. 609)



ONE METER WAVES



How to Build "Long Lines" Xmitter

● THE amateur has done little experimenting on the real ultra-high frequencies for the simple reason that proper equipment has only recently become available. It is a well-known fact that it is almost impossible to get any appreciable power from the conventional type of vacuum tube at wavelengths as short as 1 meter.

With the advent of the new Western Electric 316A tube, there is no reason why the amateur who can afford it should not carry on experiments in the 1/2 to 1 1/2-meter regions. This new tube can be operated at fairly high efficiency at 1/2-meter, and has a power output of from five to eight watts. There are many advantages in working on frequencies in the neighborhood of 300 megacycles or higher; principally the entire lack of *outside interference*.

No Interference Noticed

For instance, during the several months of experimental work, we did not hear a single automobile ignition system, or for that matter, any other type of electrical disturbance; in fact we heard nothing *save our own signals* and we believe that this real ultra-high frequency business offers the amateur an excellent opportunity for *short-range direct communication*. We further believe that a successful amateur band could be organized in these regions, and probably produce more interesting results than the present 5-meter band. Of course, the transmission range is more limited as the frequency increases and the higher we go, the more it seems to take on the *optical effect*.

In other words, in wavelengths around 1-meter, distances of around 25 miles would seem to be "DX," unless we ex-

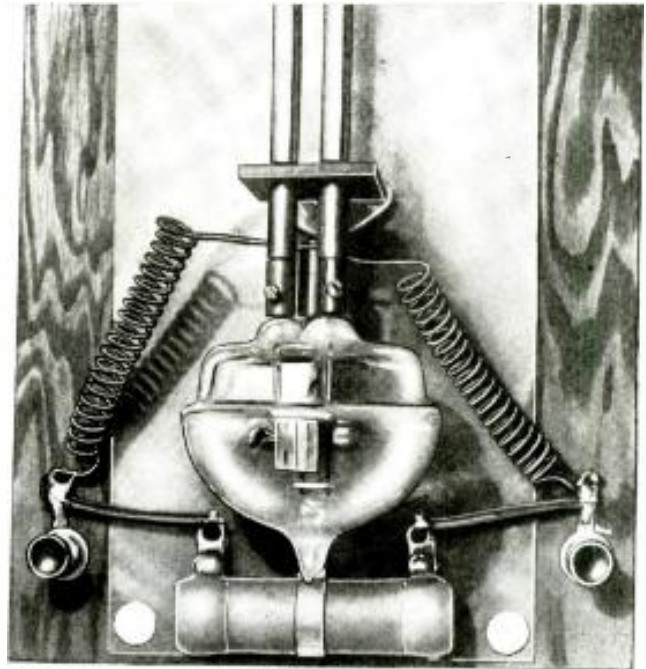

↑ Close-up of the tube showing how it's fastened to the copper rods.

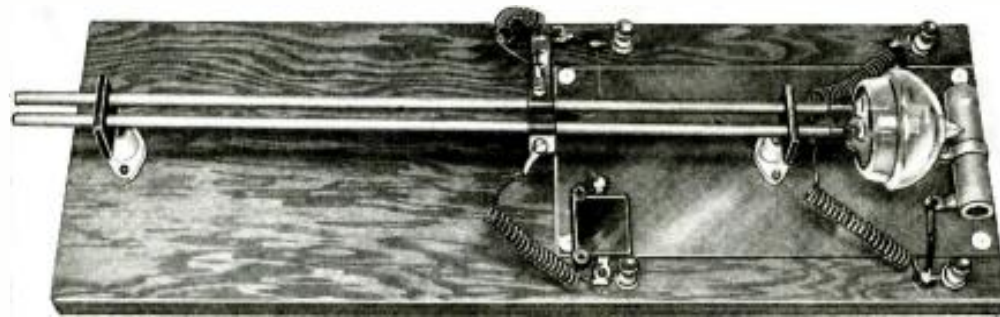

← Complete 1-meter oscillator.

perience some unusual conditions similar to those now current on the five meter band, where atmospheric conditions play a prominent part. Before any definite opinions can be reached, it will be necessary for the amateurs to occupy these high frequency regions in large numbers and thereby prove whether or not present theories and findings are definitely correct. In any event, we believe it affords an excellent opportunity for *intra-city communication*.

The transmitter employed during our experiments was a single 316A, plate-modulated with about 400-volts on the plate. In the photographs you see the actual transmitter that operated in the neighborhood of 275 megacycles. The circuit is exactly the same as that described by the author in the November 1934 issue of *Short Wave Craft*, and this circuit seems to be the only logical one at the present time for 1-meter operation.

Constructional Details

The general constructional details can be learned by referring to the photograph. Here we see that the tube is fastened to the ends of a pair of copper tubes. These tubes are 1/4-in. in diameter, and the spacing between them is slightly over a 1/4-inch. The spacing in fact is identical to the spacing of the plate and grid prongs of the tube. The length of these copper rods of course, depend upon the fre-

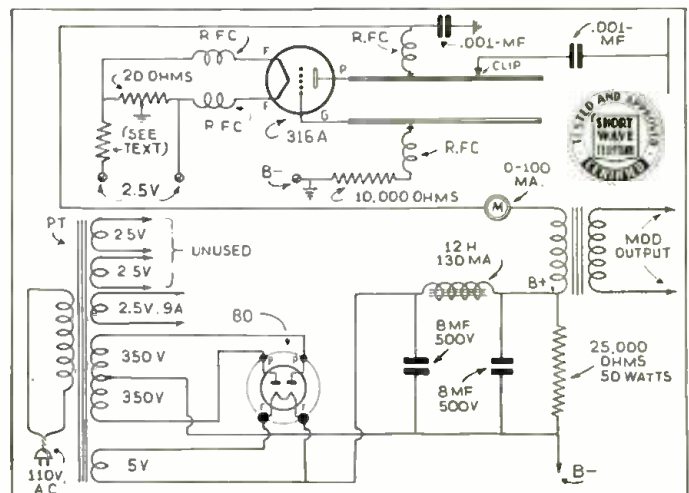

Diagram showing the transmitter connections.

for "Short Haul" QSO's

Using WE-316A Tube; Also Receiver

By George W. Shuart, W2AMN



copper electrodes. The plate and grid re-turn leads are taken from a point of zero R.F. voltage on this oscillatory line. R.F. chokes are used at this point and they consist of 20 turns of No. 18 or 20 wire, wound on 1/4-inch dowel stick. After the winding form is removed the turns are spaced so that the over-all length is approximately 2-inches. Similar chokes are also used in series with each leg of the filament circuit.

● The ultra short-waves around 1-meter offer the amateur an exceptional opportunity for interference-free communication. Of course, the distance to be covered is not great, but if a large number of amateurs should migrate to the real short-waves, unbelievable developments may take place. Complete information is given on the construction of the Transmitter and Receiver in this article.

Adjusting Transmitter

If the directions given are followed the oscillator will work the first try and no tricky adjustments will be necessary. The one and only adjustment is the placing of the grid and plate connections on the copper rods, and this is done with the aid of a small neon bulb, after the transmitter is operating and the two clips connected to about the mid-point of the copper rods. Slide the neon bulb along the rods until a point is reached where no glow is apparent. This is the point where the two clips should be attached.

The antenna used in our experiments consisted of a single copper rod one-half wavelength long. Its length was determined by the standing wave on the linear circuit of the oscillator. The distance from the free end of the copper tubes to the point where the neon bulb went out may be roughly considered as 1/4-wave, and the length of the half-wave antenna will be twice this length. The antenna feeder consisted of a single wire, tapped on to the antenna a short distance from the center. This distance is equal to approximately 14% of the total length of the antenna.



Top view of 1-meter receiver.

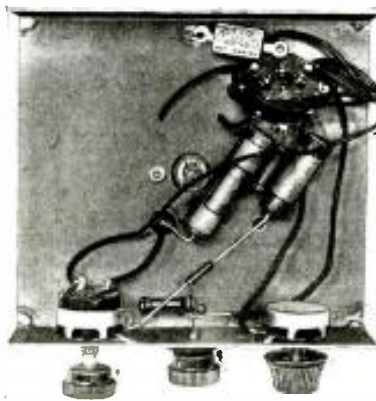

Bottom view of receiver.

1-Meter Receiver

No directional antennas were tried because the receiver was most of the time located in a moving automobile and therefore a directional antenna would not have served our purpose. The receiver employed is also shown in the photograph, and consisted of an Acorn 955 triode, and a 41 audio amplifier. The tuning condenser was a two plate Trim-air with the stator plate split in the center. Complete data is also given in the diagram covering the construction of the choke coils and the inductance for the grid circuit.

The power supply for the transmitter was a very simple affair and the diagram explains it in detail. As 2 1/2 volt windings are the nearest obtainable, in the average power transformer, a resistance is necessary in order to reduce it to 2 volts for the filament. (Continued on page 758)

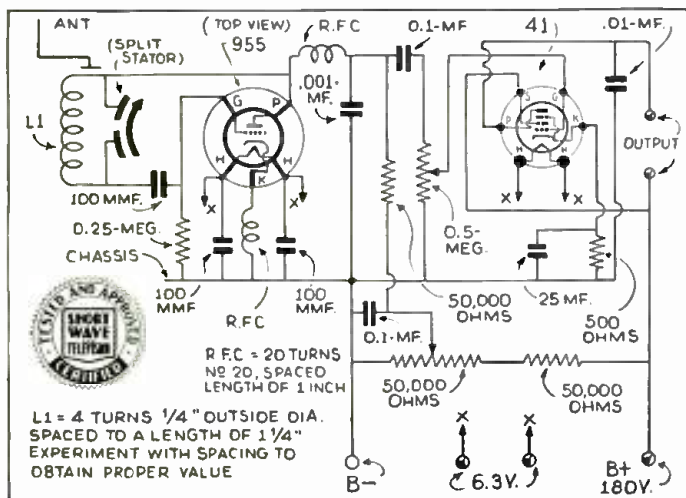

Diagram of the 1-meter experimental receiver.



The 400-volt power-supply used with the oscillator.

VIENNA

● OER2 at Vienna, Austria, has rebuilt its station and now operates daily on 11,800 kc. from 10 a.m.-5 p.m. and Saturdays till 5:30 p.m. The power is about 2 kw.

S. AMERICA

The 31 meter band is now jammed with South Americans. Almost any evening it is possible to tune in Spanish-speaking S.A.'s in the 9,500 kc. band. In addition to the more familiar "standbys" we find there now the following "newcomers."

XEFT of Vera Cruz, Mexico, on 9,490 kc. XEDQ of Guadalajara, Mex., on 9,470, HH2R of Port-au-Prince, Haiti, on 9,440 kc. and an "unknown" on about 9,445 kc. Reference to the station list will show that there are about 19 Spanish-American stations between 9,670 and 9,428 kc!



HONORARY MEMBERS

Dr. Lee de Forest

John L. Reinartz

D. E. Replogle

Hollis Baird

E. T. Somerset

Baron Manfred von Ardenne

Hugo Gernsback

Executive Secretary

Short Wave League

At a Directors Meeting held in New York City, New York, in the United States of America, the Short Wave League has elected

John F. Müller

a member of this League.

In Witness whereof, this certificate has been officially signed and presented to the above

H. Winfield Secor
Club Secretary

This is the handsome certificate that is presented FREE to all members of the SHORT WAVE LEAGUE. The full size is 7¼"x9½".

(See page 781)

CHILE

There is a new broadcaster in Santiago on about 12,300 kc. It is heard almost nightly as late as 11 p.m. Call letters are unknown but are most likely CB123, as the Chilean broadcast stations' operating frequency in megacycles, prefaced by the letters CB. (A most logical arrangement.)

VENEZUELA

All Venezuelan call letters underwent a drastic change on January first. Under the new "set-up" the various important cities are assigned certain numbers and all stations in a given city must have calls beginning with the number assigned to that city. All the new calls are not yet known, so some call-letter spaces in the station list have been left blank. The princi-

pal cities have been assigned the following numerals. 1: Maracaibo, Valera and Bocono. 2: San Cristobal and Merida. 3: Barquismeto and San Felipe. 4: Valencia and Maracay. 5: Caracas. For example YV2RC in Caracas on 5800 kc. is now YV5RC. YV5RMO on 5850 is now YV1RB.

CZECHOSLOVAKIA

OLR at Prague has been operating on another new frequency—9,550 kc. between DJA and DJN. It is heard "signing off" on this frequency at 10 p.m. on Mon. and Thurs.

THANKS

Thanks to the following contributors for information in compiling this column and the station list this month. J. Rudolph, Wis.; R. Harvey, Jamaica, B.W.I.; Theodore Smith, Ogdensburg,

WHEN TO LISTEN IN

By M. Harvey Gernsback

PANAMA

A new station is supposed to be in operation from January 15th according to information received from the operators. It is HP5L at David, Chiriqui, Panama, on 11,740 kc. Address is Apartado 129. Another Panama station is being heard irregularly on 11,795 kc. during the evening hours. It is located

at Aguadulce.

JAPAN

The new Japanese short-wave broadcast service is supposed to go into operation on April 1st. New transmitters employing 50 kw. power will be put in service. At present tests are being carried out with 20 kw. transmitters. Programs for America are broadcast daily from 12 m.-1 a.m. on either JZJ ((11,800 kc.) or JZK (15,160 kc.) from 4-5 p.m. on JZJ and either JZK or JVN. For Europe programs are transmitted on Tues. and Fri. from 2:30-3:30 p.m. on JZI, 9535 and either JVP or JZJ. Programs for Australia and New Zealand are broadcast from 9-10 a.m. on JZI and JVM or JZJ. In addition the regular Japanese long-wave program is relayed daily from 4-8 a.m. by JVN and at various intervals during other parts of the day.

N.Y.; R. B. Oxrieder, Pa.; D. J. Centanino, Pa.; C. Walter, Pa.; B. Sawada, Cal.; F. W. Hartman, N. J.; R. Havens, Mont.; C. Dye, Cal.; and Archer in far-off Johannesburg, S. Africa. Again, many thanks.

HONOLULU?

I wish to report the reception of a station in the Hawaiian Islands that has been broadcasting quite frequently in the past few months. I believe the station to be located in Honolulu, Hawaii. The station is identified by the call KKP. They are on the air every Sunday evening from 8:30 to 9 p.m. on 16.030 mc.—C. O. Downing, Dayton, O.

Here's Your Button

The illustration herewith shows the beautiful design of the "Official" Short Wave League button, which is available to everyone who becomes a member of the Short Wave League.

The requirements for joining the League are explained in a booklet, copies of which will be mailed upon request. The button measures ¾ inch in diameter and is inlaid in enamel—3 colors—red, white, and blue.



Please note that you can order your button AT ONCE—SHORT WAVE LEAGUE supplies it at cost, the price, including the mailing, being 35 cents. A solid gold button is furnished for \$2.00 prepaid. Address all communications to SHORT WAVE LEAGUE, 99-101 Hudson St., New York.

WORLD-WIDE SHORT-WAVE REVIEW

-Edited By C. W. PALMER

The "Septimetre" Receiver

● THE advancement of television in England to the point where receivers are being sold by all the larger manufacturers of radio equipment, has created a flurry of excitement among all radio listeners in that country.

For those who cannot afford one of the relatively expensive television sets, *Practical and Amateur Wireless* (London) recently featured a small receiver for pick-



Appearance of the "Septimetre" Receiver.

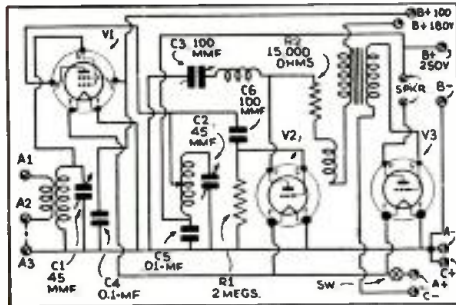

Diagram of U. H. F. receiver.

ing up the music and sounds which accompany the video (picture) programs.

Since radio fans in the U.S. may be interested in this simple little U.H.F. set, we give the circuit and constants here.

The set consists of a stage of R.F. (mainly for stability) followed by a regenerative triode A.F. amplifier. The set is battery-operated. The values of parts are indicated in the diagram and can be readily duplicated in American parts.

The coils are arranged to plug into ceramic bases with tip-jacks inserted. For the 7 meter band, the coils consist of 6 turn grid coils, wound with No. 14 bare copper wire, wound to 5/8-in. diameter and spaced slightly more than the diameter of the wire. The aerial and tickler coils are wound with 4 turns of the same size wire and wound to the same diameter and spacing.

An Australian "Champion" 3 W. Phone Xmitter

● THE *Australasian Radio World* (Sydney) featured in the past two issues details of VK2CP's phone transmitter which has worked 17 American stations on phone and over 100 American stations on C.W., operating on the 20 meter band.

For those "hams" who might be interested in the rig which VK2CP used, we are reprinting the circuit here.

A 40 meter crystal is used, giving operation on the 40 and 20 meter bands. One section of the type 53 tube is used as a

\$25.00 FOR GOOD 1-TUBE SET

● THE editors know that our short-wave set-builders and experimenters must have developed some extra fine 1-tube circuits—possibly for receiving sets, short-wave converters, etc.

We are therefore offering \$25.00 for a good 1-tube set, either in the form of a short-wave receiver or a converter. Please note that there is little use in sending in an ordinary hook-up for a 3-element tube as most of the circuits possible with these tubes have been published.

What the editors want is a *new* circuit, designed around one of the latest type tubes having a multiplicity of grids. Refer to the March issue, page 675, where a very ingenious 1-tube S-W converter circuit is given. This will give you some idea of what we are after.

As a preliminary, you may send in a diagram and a description of the set and a good clear photo or two of it. A list of parts should accompany the description and the editors, who will act as the judges, and whose opinion will be final, reserve the privilege of requiring the set to be sent to them for inspection and test if they so desire. With the dual purpose tubes now available many ideas will suggest themselves. For example—Receivers with R. F. and Detector Stages; Detector and A.F. stage; Detector and Plate-Supply Rectifier; 1-tube Super-het; Reflex set, etc.

crystal oscillator and the other as a frequency doubler. The power-amplifier stage uses a type 6P6—a high-frequency pentode. (This tube can be replaced by a 59 or other suitable type.)

Link coupling is used between the 53 and the power tube. When the bands are being changed, the link coupling is automatically coupled over to the required output of the 53, when the grid coil of the power tube is changed. This is accomplished by using two 6-pin coil forms, with the connections made in the correct manner for changing from one coupling to the other by using different pins for the two coupling link circuits.

The coils are wound as follows:

40 Meters	20 Meters
L1—19 T.	L2—10 T
L3—14 T	L3—8 T
L4—22 T	L4—12 T

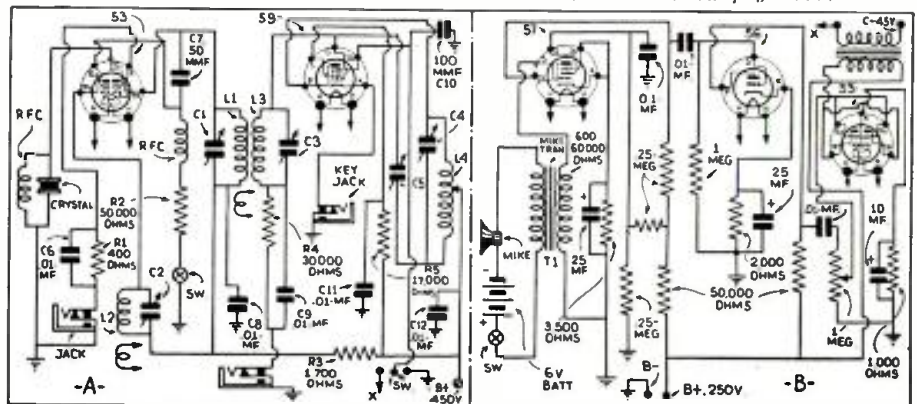

An interesting short-wave phone transmitter and modulator.

Link coils in all cases—2 T. L1, L2, L3 are wound with No. 20 D.C.C. L4 is wound with No. 8 bare copper wire.

The modulator system is a high-gain affair using a type 57 resistance-coupled to a 56, which is also resistance-coupled to the modulator—a type 53 connected as a triode. Coupling to the power stage of the xmitter is through a 1:1 class B transformer.

The power-supply (not shown) delivers 450 V. at 150 ma. This is reduced through a potential dropping resistor to 250 V. for the modulator system.

Electron-Coupling With Battery Tubes

● DIFFICULTY is sometimes encountered in obtaining satisfactory oscillation with electron-coupled oscillators on wavelengths below 30 meters, when battery type tubes are employed.

The reason for this difficulty according to an article in *Funk Magazine* (Berlin) recently is due to "stray capacities" between the filament circuits and ground. At the

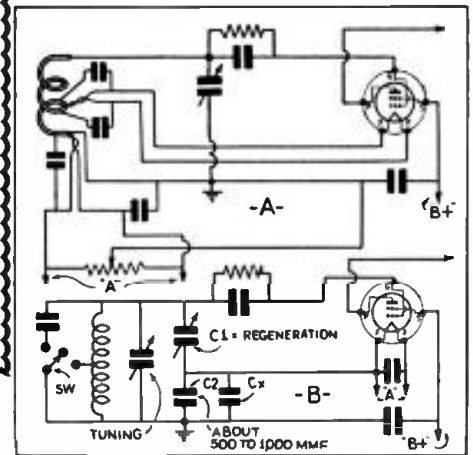

Circuit for improved oscillator on ultra short wavelengths.

very high frequencies this capacity affects the phase relation between the signals in the tuned circuit and those fed back to it. The result is that instead of aiding the currents in the tuned circuit these feed-back currents tend to oppose or reduce them.

The circuit detail at -A- shows a method of reducing this trouble by the use of hollow tubing for the tuning coil with the filament wires carried in a twisted pair through the lower portion of the coil from the point where the ordinary "cathode tap" is usually made. These leads are then

(Continued on page 777)

SHORT WAVE .

THIRTY-SEVENTH TROPHY . SCOUTS

Presented to
SHORT WAVE SCOUT
WALTER J. KULECK
57 E. Parker Street
Scranton, Pa.

For his contribution toward the
advancement of the art of Radio
by



● ON this page is illustrated the handsome trophy which was designed by one of New York's leading silversmiths. It is made of metal throughout, except the base, which is made of handsome black Bakelite. The metal itself is quadruple silver-plated, in the usual manner of all trophies today.

It is a most imposing piece of work, and stands from tip to base 22 1/4". The diameter of the base is 7 3/4". The diameter of the globe is 5 1/4". The work throughout is first-class, and no money has been spared in its execution. It will enhance any home, and will be admired by everyone who sees it.

The trophy will be awarded every month, and the winner will be announced in the following issue of SHORT WAVE & TELEVISION. The winner's name will be hand engraved on the trophy.

The purpose of this contest is to advance the art of radio by "logging" as many short-wave phone stations, amateurs excluded, in a period not exceeding 30 days, as possible by any one contestant. The trophy will be awarded to that SHORT WAVE SCOUT who has logged the greatest number of short-wave stations during any 30-day period.

88 Stations—76 Foreign

● WE take pleasure in awarding the thirty-seventh trophy to Walter J. Kuleck, Scranton, Pa., for his efforts in DXing. Mr. Kuleck rolled up an excellent list of stations, 88 in all, and all of them came within the scope of the contest rules. The receiver employed

Honorable Mention
(NONE)

was a 1936 model, 660X All-Wave 10-tube Philco superheterodyne. This, together with the 65 foot, one-wire antenna, 25 ft. high, was used for receiving.

This month was just the opposite from last month, insofar as Mr. Kuleck was the only entrant. Read the new "Continent" contest rules below, which the editors believe will make this department more interesting. Read the rules carefully and make sure that your entry complies with them.

We might offer a suggestion in sending in your entry, and that is list the stations and number them. For instance, from 1 to 75, if you have that many. Then *stack the cards in the same order* so that the judges can quickly and accurately check the list, without having to delve through a large number of cards.

Good luck, and see you next month!

Mr. Kuleck's List of Stations

Call	Freq.	Sched.	United States	Location
W2XE	11,830 kc.	Relays	WABC	Atlantic
		Broadcast.	Corp., N.Y.C.	
W3XAL	16,873 kc.	Relays	WJZ	Nat. Broad-
		casting Co.	Bound Brook, N.J.	
W9XAA	11,830 kc.	Relays	WCFL	Chicago
		Fed. Labor,	Chicago, Ill.	
W9XF	6,100 kc.	Relays	WENR	Nat. Broad-
		casting Co.	Chicago, Ill.	
W2XAF	9,530 kc.	4-12 p.m.,	ex. Sun., 4:15-	
		12 p.m.	General Electric Co.,	Schenectady, N.Y.
W2XAD	15,330 kc.	2-3 p.m.;	ex. Sun., 10:30	
		a.m.-4 p.m.	General Electric Co.,	Schenectady, N.Y.
W3XAU	9,590 kc.	Relays	WCAU	Newtown
		Square, Pa.		
W3XAU	6,060 kc.	Relays	WCAU	Newtown
		Square, Pa.		
W1XAL	6,040 kc.	World Wide Broadcasting		
		Corp., Univ. Club,	Boston, Mass.	
W1XAL	11,790 kc.	World Wide Broadcasting		
		Corp., Univ. Club,	Boston, Mass.	
W8XAL	6,060 kc.	Relays	WLW	Crosley Radio
		Corp., Cincinnati,	Ohio.	
W3XAL	6,100 kc.	(Same as above.)		

(Continued on page 770)



New "Continent" Scout Trophy Contest

● MANY of our readers have suggested that we offer a new type of contest for the Short-Wave Scout Silver Trophy. We have therefore decided to begin a new series of contests and you can start "listening in," and writing for veris at once.

This new series of contest will be confined to reception from stations at one continent at a time. The first of these contests will be for the greatest number of verified stations heard in *Asia*. You may "listen in" from now until June 25th, but you will have to allow time for veris to reach you.

The same general rules as given previously apply. That is, a notarized affidavit must be sent with the veri cards and, of course, all of the veris will have to be for the continent assigned for each particular contest. The *Asia* "listening in" contest will close June 25th, and the trophy award will be announced in the September number which goes on the newsstands August 1st.

A—By midnight June 25th, all entries for the *Asia* contest must therefore be in the hands of the Editors, together with veris and the notarized oath that the contestant personally listened to all of the stations listed.

B—For the next four issues, the May, June, July and August numbers, trophies will be awarded on the basis of the old rules, which require that 50% of the stations heard and verified be foreign, and also that the listening time may be any 30-day period. In either contest, and in the event of a tie between two or more contestants, each listing the same number of stations, the judges will award a similar trophy to each contestant so tying.

C—Bear in mind that the veri cards should be absolute verifications, and not simply an acknowledgment that you notified a station that you heard them. The B.B.C. and several other stations do not verify, but simply send an acknowledgment card. Note that in either contest that only experimental phone or broadcast stations should be entered in your list. No amateur transmitters or commercial code stations can be entered. For the May, June, July and August contests, which follow our regular rules, the entries must be in the Editors' hands by midnight of the 25th day of the month for the next succeeding issue. The contest for the May issue will close in New York City March 25th, etc.

D—Please note once more, that only letters

or cards which *specifically* verify reception of a given station on a given wavelength and on a given date will be accepted! Don't forget to send International Postal Reply Coupon, costing 9 cents at your P.O. with requests for foreign veris.

E—Any type of short or all-wave receiver may be used by the listener. Please specify type and make of set, how many tubes, type of aerial and its dimensions in a brief statement accompanying the veri cards. All veri cards will be returned prepaid after judging each contest. The judges in each contest will be the Editors of *Short Wave & Television* and the opinions of the judges will be final.

F—When sending in entries, type your list, or write in ink, and give the total number of stations both Foreign and Domestic. Send veri cards with your letter and oath certificate all in one package. Use a single line for each station and list them in a regular order, such as: frequency, schedule. (All time should be reduced to E.S.T., which is five hours behind Greenwich Meridian Time.) Name of station, city, country; musical identification signal if any.

WHAT'S NEW In Short-Wave Apparatus

The short-wave apparatus here shown has been carefully selected for description by the editors after a rigid investigation of its merits.

RSR CLIPPER

Communications Receiver Tunes from 3.5 to 555 Meters

By A. J. Haynes

A Combination Regenerative and Super-Regenerative Circuit is Employed. Band-switch is "built-in," also special band-spread feature. 5-tube set, works on 110 Vts. A.C.

● COMPROMISES are unavoidable in the design of an all-wave receiver. The problems of efficiency over the receiver's tuning range; simplicity and ease of operation; cost of production; choice of circuit and tubes and appearance of the finished set are only a few of the points the designer must consider and balance against each other.



The RSR Clipper gives surprising results with a relatively small number of tubes. The selectivity is sharp and the set has good output. (No. 605)



Rear view of the RSR receiver, showing the well-spaced arrangement of the parts. This set showed excellent DX-getting ability.

The receiver illustrated herewith was designed primarily for short-wave reception so that when any compromises had to be made they were decided in favor of the higher frequencies. Thus, while the broadcast band is included and gives a good account of itself over a reasonable distance range, by virtue of the large dynamic speaker and beam power-output tube, the receiver is most efficient on the long-distance, short-wave bands.

Circuit of High Efficiency Used

The circuit used is a modern adaptation of the electron-coupled regenerative and super-regenerative circuits combined in the same detector tube. This type of circuit was chosen in preference to the superheterodyne, because it provides a tremendous amount of amplification in proportion to the number of tubes and parts used, thus permitting excellent long-distance reception at a minimum cost. High quality component parts can be used and still keep the cost low, for they are few in number. Moreover as a minimum of tubes and parts are employed the noise-level in the receiver itself is extremely low.

Three of the five tubes used in this new receiver deserve special mention: Two of these tubes are the new Sylvania 6J5G high frequency Super-Triodes which are employed in the detector and first audio amplifier. Beside being an unusually fine amplifier this tube's unique characteristics make it an ideal regenerative and super-regenerative detector for the high and ultra-high frequencies. The third new tube used is the 6L6 beam power-output tube, which deserves all the praise it has received since its introduction. This tube, as used here, is held down to about four watts output, as this is more than adequate, even for the heavy duty six-inch dynamic speaker being used. At this power output the 6L6 just loafs along and consequently produces excellent quality with low harmonic content.

Combination Regen. and Super-Regen. Principles Used

A combination regenerative and super-regenerative circuit is used, employing a form of electron-coupling in the detector. This reactive circuit is so stable and its regenerative control has so little effect on the grid circuit tuning, that it can be successfully calibrated from the top of the broadcast band down to 13½ meters. This is done in four separate bands on the main tuning dial. The smaller center dial, which tunes a three-plate, Isolantite insulated condenser, acts as band-spread over this whole tuning range. Beside this electrical band-spread, both dials have mechanical reduction drives. This combination gives really adequate band-spread, even for twenty meter CW work.

As indicated on the schematic diagram (Continued on page 769)

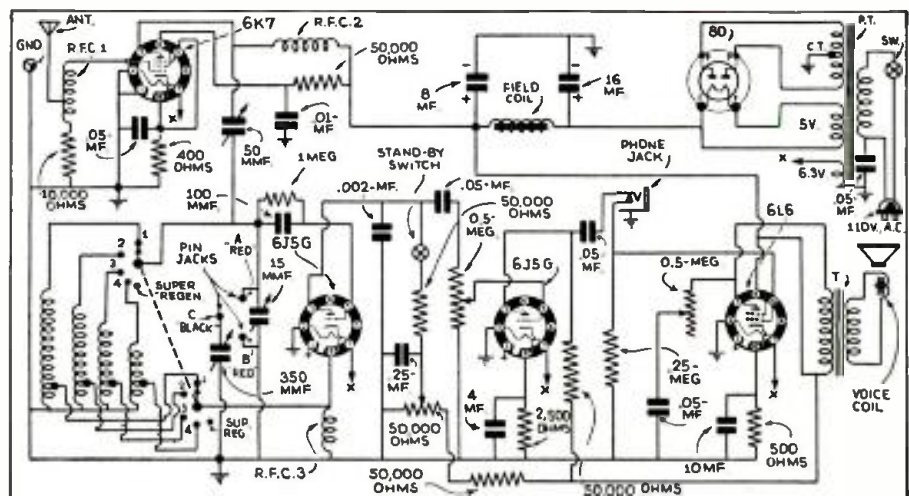

Wiring diagram of the RSR receiver.

Names and addresses of manufacturers of apparatus furnished upon receipt of postcard request; mention No. of article.

The "Sky-Challenger"—Range 38.1 mc. to 545 kc.

● DESIGNED by one of the leading manufacturers of communications receivers in the country, this receiver—the Sky-Challenger—has every feature desirable in a receiver of its type plus broadcast reception of startling quality. The frequency range (changed by band-switch) of this new unit is from 38.10 mc. to 545 kc. in five bands. It seems the *Hallcrafters* sounded the needs of the listener more deeply than by merely turning out a radio receiver capable of bringing them in from all over the world; here is a receiver which appeals to the taste and principally the pocketbook of not only the discriminating amateur but the more advanced short-wave listener.

To afford the listener as image-free performance as possible, a tuned stage of radio frequency amplification is used on all bands. On the higher frequency ranges of the receiver this stage, normally found only in the more expensive all-wave receivers, justifies itself by giving gains in the order of 3 to 1. A separate oscillator tube is used in all ranges rather than sacrifice performance by using harmonics. The superior over-all performance obtained by using separate coil and tube would allow no substitution in a receiver which was to economically fill every listener requirement.

Iron-core intermediates which had so definitely demonstrated their superiority in the more expensive models of this line of receivers couldn't be left out. To get that high order of selectivity so necessary in communications receivers, two I.F. stages are used, both of them iron-core. For the QRM ridden ear of the active amateur, the 465 kc. crystal filter model is available, while for the short-wave listener satisfied with nothing but the last word in performance, the conventional model—less the crystal—is optional. Under test it is surprising how the crystal model



The new 9-tube Superheterodyne Receiver has five bands, all "switch-controlled." Excellent for "Fan" or "Ham" purposes. Available with or without crystal filter. For complete diagram see page 756. (No. 602)

sets them up like sore thumbs with no interference to bother a perfect QSO. One very necessary requirement has not been neglected—a separate band-spread control. It proved to be a pleasure to comb across the band in a few effortless turns of this control, and still be able to resonate accurately and comfortably on any one signal. It was found that more than normal caution had to be taken with the crystal in the circuit; a little careful tuning uncovered signals which had previously been completely overlooked—that might give you an idea just how selective this new set really is.

As indicated in the diagram, the tube line-up is as follows: a 6K7 R.F. amplifier or pre-selector, a 6L7 first detector mixer, a 6C5 signal frequency oscillator, 6K7 1st I.F. amplifier, 6K7 2nd I.F. amplifier, 6Q7G 2nd detector, AVC 1st stage of audio, 6F6G 2nd stage of audio, 6K7 beat oscillator, and an 80 rectifier.

One thing about this receiver that appealed to us was that the speaker is not a portion of the power supply. The permanent magnet speaker provided remarkably good quality when used, but we preferred headphones when putting the receiver through its paces on DX.

Technical Description

The new 1937 Sky-Challenger is a 5 band, 9 tube superheterodyne receiver covering the following frequency ranges:

No. 1 Band—	545 KC to 1230	KC (550 to 243 meters.)
No. 2 "	1.18 MC to 2.85	MC (254 to 105 meters.)
No. 3 "	2.75 MC to 6.82	MC (109 to 44 meters.)
No. 4 "	6.75 MC to 16.40	MC (45 to 18.3 meters.)
No. 5 "	15.40 MC to 38.10	MC (19.5 to 7.85 meters.)

No. 1 Band covers the American (Continued on page 763)

New Devices for the S-W Experimenter

Sensitive Circuit-Breaker Safeguards Tubes



(No. 603)

● COSTLY tubes, transformers and condensers need no longer be junked through accidental overloads or short-circuits. The ingenious fully-magnetic, non-thermal circuit-breaker available in capacities ranging from 50 milliamperes up to 35 amperes, fully safeguards the radio amateur's major investment at insignificant cost.

The circuit-breaker has a tumbler handle, switching current on and off under normal circuit conditions. There are two types: instantaneous trip and time-delay action. The latter is provided with a hermetically-sealed magnetic trip which ruptures the circuit in from 5 seconds up to 8 minutes on a 125% load, or correspond-



Interior mechanism of new circuit-breaker.

ingly faster on greater overloads, depending on which of four-time-overload curves is selected. On short-circuits, it trips within 1/2 cycle on A.C., or 1/100 second on D.C. The instantaneous trip type may be adjusted for plus or minus 20% of rating.

Precise operating characteristics insure real protection for delicate tube filaments and associated equipment. Being fully magnetic and thereby free from usual bi-metallic strips or solder ratchets, the operation is accurate and lightning fast. It is unaffected by ambient temperature and reasonable vibration. Also, the circuit-breaker can be immediately closed after tripping on any overload or short-circuit, providing the abnormal condition no longer exists. The switch handle is simply thrown back to the "on" position.

For typical radio work, the bakelite enclosed, exposed-mounting type is offered, measuring 4 1/2 x 2 5/8 x 3 3/4 inches. It mounts on switchboard, panel, control desk or other equipment. A behind-the-panel mounting unit is likewise available. Also two and three-pole units in steel safety cabinets. These units are relatively inexpensive, and soon pay for themselves in the equipment they guard against burnouts.

Our Information Bureau will gladly supply manufacturers' names and addresses of any items mentioned in SHORT WAVE & TELEVISION. Please enclose stamped return envelope.

Low-Loss Inductors

● IN the accompanying illustration we find a new Low-Loss Inductor. This offers the amateur an opportunity to purchase his air-wound coils ready made. The coils are wound with bright copper wire protected from oxidation by a coating of colorless baked enamel. This wire is cemented in slots in narrow strips of cellulose acetate. The choice of clear enamel

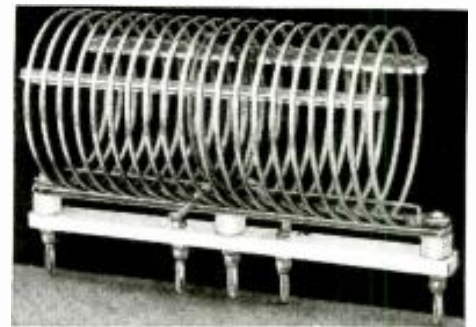

Latest design of Low-Loss Inductance.

enhances the appearance of the coil to a considerable extent. The base of the coil is low loss steatite and GR type plugs are employed to permit quick changing of the coils. The receptacle into which this coil is mounted is also shown in the photograph. These coils are available in various sizes and in six styles ranging from 160-meters down to 10.

Our information bureau will gladly supply manufacturers' names and addresses of any items mentioned in SHORT WAVE & TELEVISION. Please enclose a stamped return envelope.



Support for Low-Loss Inductance, fitted with pin-jacks. (No. 601)

Names and addresses of manufacturers of apparatus furnished upon receipt of postcard request; mention No. of article.

Hams Will Find These New Tubes Useful

New Raytheon 6V6G Beam Tube



New "Beam" tube. No. 606

● THE 6V6G is a lined-up grid beam type tube similar in principle to the 6L6 and 6L6G. Its filament current has been kept down to .45 amperes; its power sensitivity is nearly double that of conventional pentode, and its overall plate efficiency about 30% greater than a pentode. Added to high power and efficiency, the 6V6G has been designed to keep objectionable odd harmonic distortion down to a very low value.

The tube offers distinct advantages used single ended or a pair in auto receivers, and will also fill the long standing gap between the 6F6G and 6L6G in home receivers.

This new Raytheon 6V6G is suitable for class B audio amplifiers in the same manner as the 6L6, only, of course, the outputs would be considerably lower. Complete class B characteristics are not available at this writing. However, we have had an opportunity of using this tube as a crystal oscillator and find it's exceptionally well suited to this purpose with 300- to 350-volts to a plate. The output was considerably greater with the conventional pentode such as the 2A5, 42, 47, and other equivalents.

Operating Conditions—Amplifier—Class A
 Plate 250 volt
 Screen 250 volt

Grid	—12.5	volt
Peak Signal	12.5	volt
Plate Current (no signal)	45	ma.
Plate Current (max. signal)	47	ma.
Screen Current (no signal)	4.5	ma.
Screen Current (max. signal)	6.5	ma.
Load Resistance	5000	ohms.
Power Output	4.25	watt
Second Harmonic	4.5	%
Third Harmonic	3.5	%
Heater Voltage	6.3	volts
Heater Current	0.45	amperes

This article has been prepared from data supplied by courtesy of Raytheon Production Corp.

"A Word to the Wise is Sufficient"

● MANY of the newer tubes on the market have their plate terminals coming out of the glass envelope in the form of a thin wire and do not employ the metal cap such as we find on some of the older type tubes. The reason this cap is not employed is because the terrific heat following through the plate connection which usually supports the plate, melts the solder with which these caps are secured unless they are equipped with large metal plates in order to dissipate the heat.

It is quite possible using one of these tubes to actually melt the glass if the tube is overdriven to a point where the plate becomes excessively hot or when tuning one might have an off-resonant condition causing the plate to become hot enough to melt the glass (tuning should be done with reduced voltage). Once this glass becomes softened the tube will collapse because of the extremely high vacuum and thus the tube is ruined.

This can all be avoided if the following precautions are taken:

Use a heavy metal connector to the plate pin and preferably the connection between the plate terminal, and the tank
 (Continued on page 760)

EIMAC 35-T

● THIS new EIMAC 35-T is excellently suited for R.F. and audio purposes. As can be seen from the accompanying table outputs from 112 watts R.F. are obtainable from a single tube and 140 watts are obtainable from a class B push-pull audio amplifier. Also due to the design of these tubes they are exceptionally useful at high frequencies. The plate and grid are constructed from tantalum, an excellent metal for the purpose, and the use of which entirely eliminates the necessity of a "getter" in order to maintain the proper vacuum.

EIMAC 35-T—Characteristics

Filament voltage	5 volts
Filament current	4 amperes
Amplification factor	30
Maximum plate current	125-150 milliamperes
Plate voltage	200-1500 volts
Plate dissipation	35-70 watts on cw.
Grid-plate capacity	2 mmf.
Base	Standard UX-1 prong
Height-Overall	5 1/2 inches
Maximum diameter	1 3/4 inches

(Cont'd on page 760)

This 35-T tube is very useful for high frequencies. (No. 607)



A close-up of one of the tuning coils.

● SINCE the publication of new "Super Pro" articles in the February and March issues of *Short Wave & Television*, I have received so many letters requesting further data on design and constructional phases that I am devoting most of this discussion to the answering of these inquiries and I am including, too, other details that I believe will prove interesting.

Many asked me to further describe the cam knife-switch that is used in the "Super Pro," particularly requesting details on its actual operation. Each section of this

Additional Features in New SUPER PRO

By Donald Lewis

switch constitutes a two-pole five-position unit. The silver-plated knives which are mounted on bakelite panels sliding in guides and raised and lowered by cams on the switch shaft, eliminate the necessity for pigtailed, wiping rotary contacts and even the pivot of the knife blade, the chief source of trouble in the standard knife switch.

In the illustration, the various components of this switch are clearly shown; viz. the brass cam, bakelite knife with its silver-plated edge, the sturdy switch housing and the silver-plated contacts which, as will be noted, are split to provide triple contact. It will be noted, too, that the rotating rod is a square design affording a most positive grip for the knob and preventing slipping of any kind. Silver-plated short-circuiting springs automatically short the four open contacts at all times, thus further eliminating all losses.

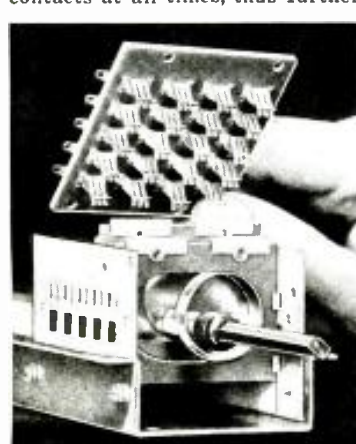

Cam and switch unit. (No. 608)

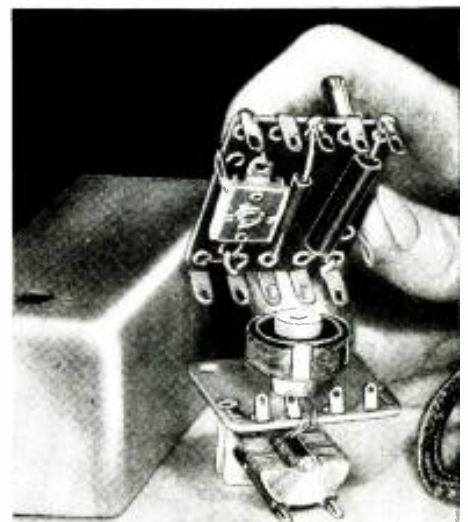

Second detector output coil unit.

The timing of the cams and arranging of the contacts is such that the circuit through one setting of knives is not broken until contact is made with another set. This avoids sparking in the sections which handle plate current and also prevents open grid circuits when the switch is turned.

Another letter I received asked for the capacity of each section of the tuning condenser and a few mechanical details involving its construction. Each section of this condenser has a capacity of 180 mmf. The rotor plates are the Midline type affording a very uniform frequency scale for the two to one range used in the receiver. The rotor shaft is of stainless steel. The stators are mounted in isolantite blocks. The rear bearing is a single steel ball between a cupped adjusting screw and a cupped depression, located in the end of a rotor shaft. (Continued on page 761)

Names and addresses of manufacturers of apparatus furnished upon receipt of postcard request; mention No. of article.

5 & 10-Meter Transmitter

This crystal-controlled high frequency transmitter will appeal to many "Flams," and it may be built at a very nominal cost. The tubes used are as follows: 6A6 as oscillator-multiplier; 802 as intermediate amplifier; a pair of 210's as the final push-pull amplifier. Excellent operating results were obtained by the author with this transmitter, including contacts with countries across the Pacific.

unit to read all plate values. Closed-circuit jacks were wired in series with each tube plate.

One milliammeter could very easily be used to read all circuits but the author had several meters available and meters add to the appearance of the transmitter, so a 0-200 m.a. meter was mounted on the final amplifier panel to read the grid and plate values of the two 210s.

Panels—How Made

The panels were cut from quarter inch hard-tempered masonite obtainable at lumber yards. The driver and final amplifier panels measure 19" x 9". The front surfaces should be sanded with fine sand paper, the edges beveled, and after cutting the hole for the meter give the panels three coats of gray enamel. Each coat of paint should be given ample time to dry and rubbed down with oil and fine sand paper before applying the next coat. The finished panels have the appearance of gray lacquered metal.

The coils for the exciter unit are all wound on Hammarlund, 1 and ½ inch diameter, coil forms. The exact winding information is given in the coil table.

A single 600 volt power supply with a tap at 350 and 450 volts is used to supply power to all tubes in this R. F. unit.

When operating on the 5-meter band it is advisable to reduce the plate voltage on the 802 to 450 volts.

The transmitter described uses an X-cut crystal operating at 7114 K.C.

Tuning Procedure

It is advisable to first tune the transmitter for the 10-meter band. With all 10-meter coils in place and filament-heater voltage on, apply the 350 volts to the crystal oscillator and multiplier (6A6) plates. With the meter plug in the oscillator jack and with the aid of a small single-turn coil and 6.3 volt lamp near the top of the oscillator's plate coil, tune to resonance as indicated by a maximum peak of the meter to about 20 m.a. and a maximum brilliance of the small lamp. The regeneration condenser on the multiplier should be set at about a quarter of the way in and with the meter plug in the second or multiplier jack and the small lamp and coil on top the multiplier coil tune the multiplier plate condenser for resonance as indicated by maximum brilliance of the small lamp and a minimum reading on the meter. With the meter and lamp still set for the multiplier, go back over the oscillator and regeneration condensers for a better setting as indicated by greater brilliance of the lamp. The 802 is now ready to drive so add plate voltage and with the meter plug in the 802's plate jack and the lamp and coil near the 802's plate coil, tune

for resonance as indicated by a minimum dip of the meter to about 40 m.a. and lots of light on the small lamp. The plate coil may require slight changes as I have the dial set at almost minimum on the plate tuning condenser.

Neutralizing "Final" Stage

With the link to the final amplifier in place, the final stage is ready to *neutralize*. Plug one of the meter plugs in the grid jack of the final and with the grid coil and condenser set at resonance (use small lamp and condenser near grid coil) tune the plate coil and condenser through (*Continued on page 766*)

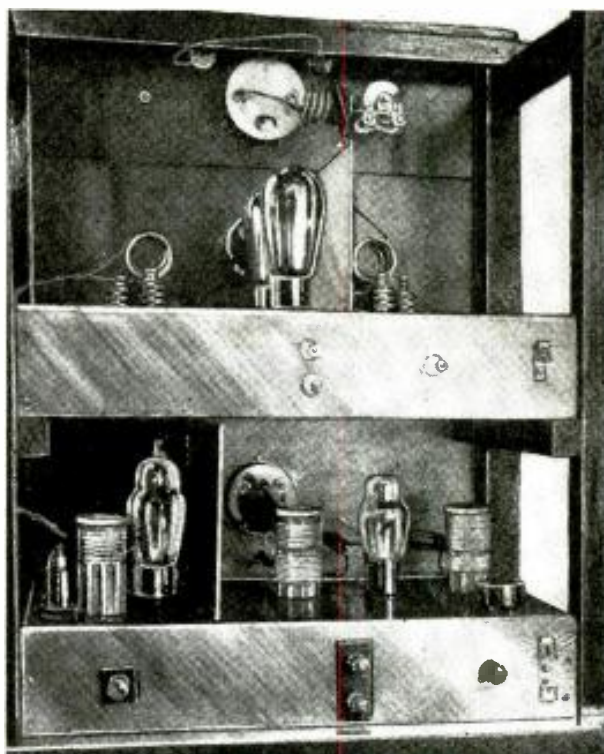

The rear view of the 5 and 10-meter transmitter.

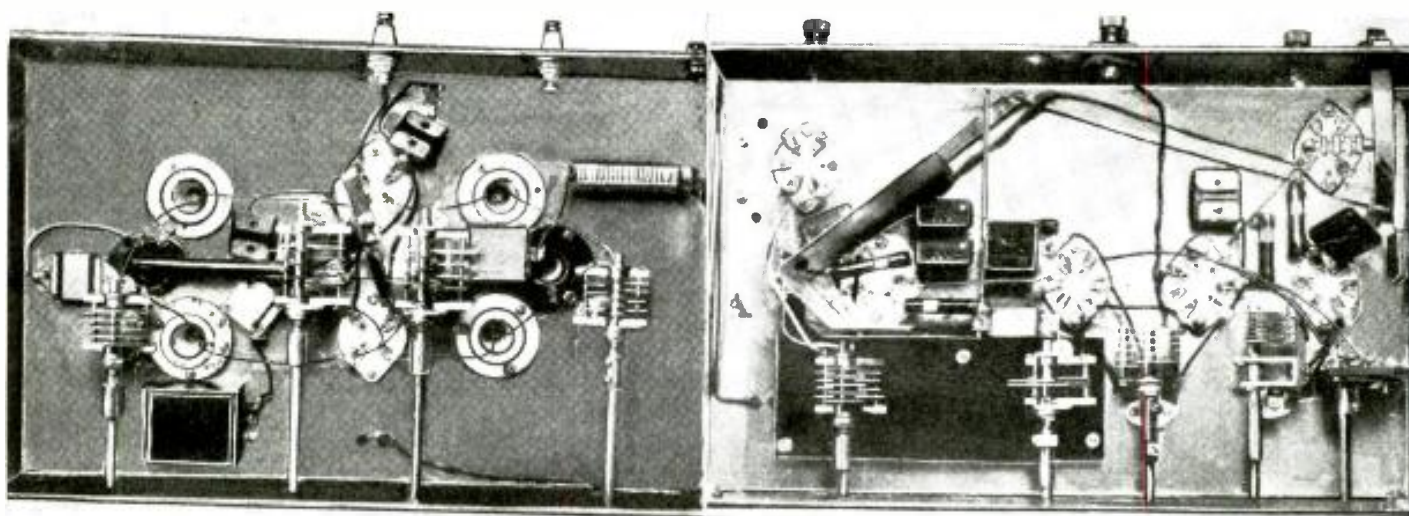

Photo at left shows bottom of the final amplifier, and illustration at right shows bottom view of the "driver."

"Movie Dial" Projects Call Letters on Screen



Appearance of the Movie Dial mechanism which projects greatly enlarged call-letters and frequency on a screen in the front of the radio cabinet.

● IN the *Movie Dial*, a mid-western radio set manufacturer presents an entirely new and unique method of indicating the tuning of a radio receiver.

The method is to project onto a ground-glass screen the image of the figures on the dial. The figures are printed photographically on a motion picture film, and projected and enlarged in a manner similar in principle to motion picture projection.

This permits enlarging the dial so that the call letters and cities of 130 broadcast stations in the United States and Canada may be shown, each call letter being about $\frac{3}{4}$ " long.

The stations are divided into three groups, East, Central, and West, so that the dial may be used in any part of the country.

The dial scale is printed on a strip of motion picture film and is mounted on a drum which rotates in synchronism with the tuning condenser. A special projector lamp is mounted in the center of the drum. The light from the lamp passes successively through a condenser lens, the dial film, a color filter, and a projector lens, and is then reflected from a mirror onto the screen. The optical magnification of this system is about 10 times. If the entire length of the enlarged scale were visible at once, it would be more than seven feet long!

When the band change switch is rotated the entire film drum is moved vertically, so that a new scale is projected on the screen. At the same time the color filter is changed

to provide green and amber coloring on the two short-wave bands.

The short-wave bands contain a wealth of interesting information on the services available in these portions of the frequency spectrum. A large number of the principal short-wave stations are listed, together with their call letters and country. The location of (Continued on page 770)

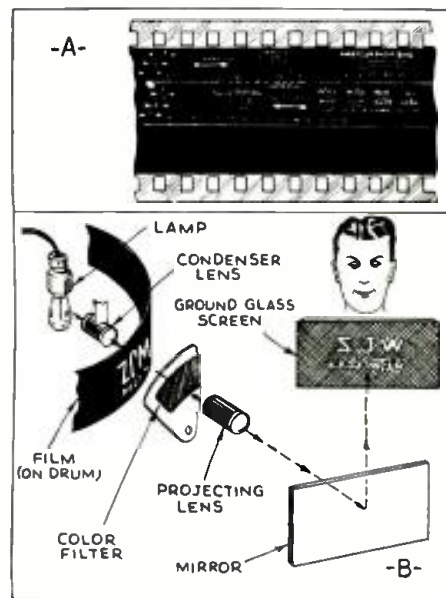

Diagram showing optical system used in the *Movie Dial* call-letter indicator. (No. 601)

How To Build A VOLUME EXPANDER

That Works

By L. A. de Rosa, E.E.

● WITH the advent of high fidelity receivers, engineers have worked along every road, no matter how narrow, as long as it led to a more natural and higher quality reproduction.

One of the most noticeable faults with radio reception and one which radio engineers have attempted to remedy for some time, is that variations in loudness as they occur in the broadcast studios, are not faithfully reproduced at the receiving end. An orchestra, when it goes from a very soft passage to one in which

every instrument is playing as loudly as possible, certainly is a disappointment to the critical listener. Instead of the thrill which a sudden increase or crescendo should give, the reproduction sounds as if the main portion of the power were being absorbed somewhere, and, while the listener senses from the strained quality

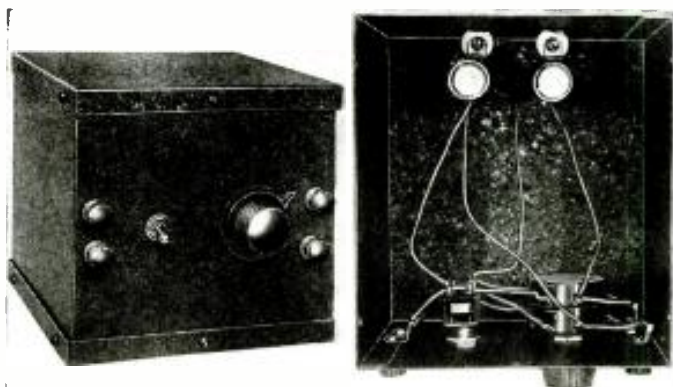

Front and "inside" views of "Volume Expander." (No. 600)

of the music that every instrument is playing as loudly as possible, there is but little change in volume. It is amazing to note that an orchestra, when it passes from a very soft to a very loud passage, increases its power about ten million times, that is, a change of 70 db.

Even a man in ordinary conversation may change the level of his voice 500,000 times, from about .01 microwatts to 5,000 microwatts, a difference of 57 db. There is no evidence of these differences in level in radio or phonographic reproduction. The leveling off of the dynamic peaks of both radio and phonograph reproduction is the work of the operator in the control booth at the transmitting or recording end, a well-meaning fellow who is more or less a necessary evil.

It is evident that in the broadcasting station if the transmitter were adjusted so that it would not overload on the loudest parts of the program, then, when the softer passages were being transmitted the modulation would be so small that static and other noise interference would drown out the program. (Continued on page 779)

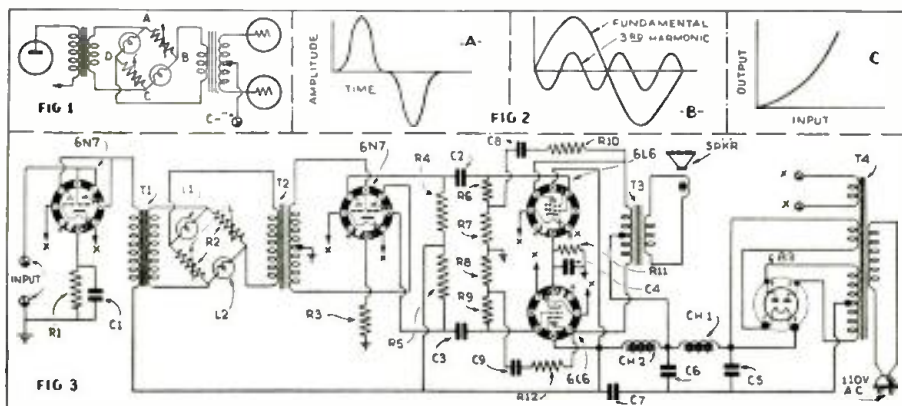

Diagram showing how "Volume Expander" is connected in audio amplifier circuit. Figure 2 shows the distortion introduced by an expander circuit having an insufficient time lag. Fig. 1 shows simplified expander circuit.

Names and addresses of manufacturers of apparatus furnished upon receipt of postcard request; mention No. of article.



World S-W Station List

Complete List of Broadcast, and Telephone Stations

All the stations in this list use telephone transmission of some kind. Note: Stations marked with a star ★ are the most active and easily heard stations and transmit at fairly regular times. Please write to us about any new sta-

tions or other important data that you learn through announcements over the air or correspondence with the stations. Stations are classified as follows: C—Commercial phone. B—Broadcast service. X—Experimental transmissions.

Around-the-Clock Listening Guide

It is a good idea to follow a general schedule as far as wavelength in relation to the time of the day is concerned. The observance of these simple rules will save time.

during bright daylight, listen between 13 and 19 meters (21540 to 15800 kc.) To the east of the listener, from about 11 a.m.-5 a.m., the 19-35 meter will be found very productive. To the west of the listener this same

band is generally found best from about 12 m. until 7 a.m. (After dark, results above 35 meters are usually much better than during daylight.) These general rules hold for any location in the Northern Hemisphere.

Short-Wave Broadcasting, Experimental and Commercial Radiophone Stations

NOTE: To convert kc. to megacycles (mc.) shift decimal point 3 places to left: Thus, read 21540 kc. as 21.540 mc.

<p>31600 kc. W2XDU -BX- 9.494 meters ATLANTIC BROADCASTING CO., 485 MADISON AVE., N.Y.C. Relays WABC daily 5-10 p.m. Sat., Sun. 12:30-5, 6-9 p.m.</p> <p>31600 kc. W4XCA -BX- 9.494 meters MEMPHIS, TENN. Relays WMC daily</p> <p>31600 kc. W8XAI -BX- 9.494 meters STROMBERG CARLSON CO. ROCHESTER, N.Y. Relays WHAM daily 7:30 a.m.-12.05 a.m.</p> <p>31600 kc. W8XWJ -BX- 9.494 meters PENOBSCOT TOWER DETROIT, MICH. Daily 6 a.m.-12:30 a.m. Sun. 8 a.m.-12 M.</p> <p>31600 kc. W6XKG -BX- 9.494 meters LOS ANGELES, CAL. Relays KGFJ Mon. 11:30 a.m.-1:30 p.m.</p> <p>31600 kc. W9XPD -BX- 9.494 meters ST. LOUIS, MO. Relays KSD daily</p> <p>21540 kc. W8XK -B- 13.93 meters WESTINGHOUSE ELECTRIC PITTSBURGH, PA. 7-9 a.m.; relays KDKA</p> <p>21530 kc. GSJ -B- 13.93 meters DAVENTRY B.B.C., BROADCASTING HOUSE, LONDON, ENGLAND</p> <p>21520 kc. W2XE -B- 13.94 meters ATLANTIC BROADCASTING CORP. 485 Madison Ave., N.Y.C. Relays WABC 7:30 a.m.-1 p.m.</p> <p>21470 kc. ★GSH -B- 13.97 meters DAVENTRY B.B.C., BROADCASTING HOUSE, LONDON, ENGLAND 6-8:45 a.m., 9 a.m.-12 n.</p> <p>21420 kc. WKK -C- 14.01 meters AMER. TEL. & TEL. CO., LAWRENCEVILLE, N. J. Calls S. America 8 a.m.-4 p.m.</p> <p>21080 kc. PSA -C- 14.23 meters RIO DE JANEIRO, BRAZIL Works WKK Daytime</p> <p>21060 kc. WKA -C- 14.25 meters LAWRENCEVILLE, N. J. Calls England noon</p> <p>21020 kc. LSN6 -C- 14.27 meters HURLINGHAM, ARG. Calls N. Y. C. 8 a. m.-5 p. m.</p> <p>20860 kc. EHY-EDM -C- 14.38 meters MADRID, SPAIN Works S. America, mornings.</p>	<p>20700 kc. LSY -C- 14.49 meters MONTE GRANDE ARGENTINA Tests irregularly</p> <p>20380 kc. GAA -C- 14.72 meters RUGBY, ENGLAND Calls Argentina, Brazil, mornings</p> <p>20040 kc. OPL -C- 14.97 meters LEOPOLDVILLE, BELGIAN CONGO Works with ORG in morning</p> <p>20020 kc. DHO -C- 14.99 meters NAUEN, GERMANY Works S. America, mornings</p> <p>19900 kc. LSG -C- 15.08 meters MONTE GRANDE, ARGENTINA Tests irregularly, daytime</p> <p>19820 kc. WKN -C- 15.14 meters LAWRENCEVILLE, N. J. Calls England, daytime</p> <p>19680 kc. CEC -C- 15.24 meters SANTIAGO, CHILE Works Buenos Aires and Colom- bia daytime</p> <p>19650 kc. LSN5 -C- 15.27 meters HURLINGHAM, ARGENTINA Calls Europe, daytime</p> <p>19620 kc. VQG4 -C- 15.28 meters NAIROBI, KENYA, AFRICA Calls London 7:30-8 a.m.</p> <p>19600 kc. LSF -C- 15.31 meters MONTE GRANDE, ARGENTINA Tests irregularly, daytime</p> <p>19480 kc. GAD -C- 15.4 meters RUGBY, ENGLAND Works with Kenya, Africa, early morning</p> <p>19355 kc. FTM -C- 15.50 meters ST. ASSISE, FRANCE Calls Argentine, mornings</p> <p>19345 kc. PMA -B.C- 15.51 meters BANDOENG, JAVA Calls Holland early a.m. Broadcasts Tues., Thur., Sat., 10:00-10:30 a.m. Irregular</p> <p>19260 kc. PPU -C- 15.58 meters RIO DE JANEIRO, BRAZIL Works with France mornings</p> <p>19220 kc. WKF -C- 15.60 meters LAWRENCEVILLE, N. J. Calls England, daytime</p> <p>19200 kc. ORG -C- 15.62 meters RUYSELEDE, BELGIUM Works with DPL mornings</p> <p>19160 kc. GAP -C- 15.68 meters RUGBY, ENGLAND Calls Australia, early a.m.</p>	<p>19020 kc. HS8PJ -B- 15.77 meters BANGKOK, SIAM Mon. 8-10 a.m.</p> <p>18970 kc. GAQ -C- 15.81 meters RUGBY, ENGLAND Calls S. Africa, mornings</p> <p>18890 kc. ZSS -C- 15.88 meters KLIPHEUVEL, S. AFRICA Works Rugby 9-10 a.m.</p> <p>18830 kc. PLE -C- 15.93 meters BANDOENG, JAVA Calls Holland, early a. m.</p> <p>18680 kc. OCI -C- 16.06 meters LIMA, PERU Works various S.A. stations daytime</p> <p>18620 kc. GAU -C- 16.11 meters RUGBY, ENGLAND Calls N. Y., daytime</p> <p>18480 kc. HBH -X- 16.23 meters RADIO NATIONS GENEVA, SWITZERLAND Broadcasts special events irregularly</p> <p>18345 kc. FZS -C- 16.35 meters SAIGON, INDO-CHINA Phonies Paris, early morning</p> <p>18340 kc. WLA -C- 16.36 meters LAWRENCEVILLE, N. J. Calls England, daytime</p> <p>18310 kc. GAS -C- 16.38 meters RUGBY, ENGLAND Calls N. Y., daytime</p> <p>18299 kc. YVR -C- 16.39 meters MARACAY, VENEZUELA Works Germany, mornings</p> <p>18250 kc. FTO -C- 16.43 meters ST. ASSISE, FRANCE Calls S. America, daytime</p> <p>18200 kc. GAW -C- 16.48 meters RUGBY, ENGLAND Calls N. Y., daytime</p> <p>18135 kc. PMC -C- 16.54 meters BANDOENG, JAVA Phonies Holland, early a. m.</p> <p>18115 kc. LSY3 -C- 16.56 meters MONTE GRANDE, ARGENTINA Tests irregularly</p> <p>18040 kc. GAB -C- 16.63 meters RUGBY, ENGLAND Calls Canada, morn. and early aftn.</p> <p>17810 kc. PCV -C- 16.84 meters KOOTWIJK, HOLLAND Calls Java, 6-9 a. m.</p> <p>17790 kc. ★GSG -B- 16.86 meters DAVENTRY B.B.C., BROADCASTING HOUSE, LONDON, ENGLAND 2-4, 6-8:45 a.m.</p>	<p>17785 kc. JZL -B- 16.87 meters TOKIO, JAPAN Tests irregularly</p> <p>17780 kc. ★W3XAL -B- 16.87 meters NATIONAL BROAD. CO. BOUND BROOK, N. J. Relays WJZ. Daily exc. Sun. 9 a.m.-5 p.m.</p> <p>17775 kc. ★PHI -B- 16.88 meters HUIZEN, HOLLAND Daily exc. Tues, Wed. and Thur. 7:30-9:30 a.m. Sun. from 6:30 a.m.</p> <p>17760 kc. ★W2XE -B- 16.89 meters ATLANTIC BROADCASTING CORP. 485 Madison Ave., N.Y.C.</p> <p>17760 kc. DJE -B- 16.89 meters BROADCASTING HOUSE BERLIN, GERMANY 12:05-5:15, 5:55-11 a.m.</p> <p>17760 kc. IAC -C- 16.89 meters PISA, ITALY Calls ships, 8:30-7:30 a. m.</p> <p>17755 kc. ZBW5 -B- 16.9 meters P.O. Box 200 HONGKONG, CHINA Irregular 11:30 p.m.-1:15 a.m., 4-10 a.m.</p> <p>17741 kc. HSP -C- 16.91 meters BANGKOK, SIAM Works Germany 4-7 a.m.</p> <p>17650 kc. XGM -C- 17 meters SHANGHAI, CHINA Works London 7-9 a.m.</p> <p>17520 kc. DFB -C- 17.12 meters NAUEN, GERMANY Works S. America near 9:15 a.m.</p> <p>17480 kc. VWY2 -C- 17.16 meters KIRKEE, INDIA Works Rugby 7:30-8:15 a.m.</p> <p>17310 kc. W3XL -X- 17.33 meters NATIONAL BROAD. CO. BOUND BROOK, N. J. Tests irregularly</p> <p>17120 kc. WOO -C- 17.52 meters A. T. & T. CO., OCEAN GATE, N. J. Calls ships</p> <p>17080 kc. GBC -C- 17.58 meters RUGBY, ENGLAND Calls Ships</p> <p>16385 kc. ITK -C- 18.31 meters MOGADISCIO, ITAL. SOM- ALILAND Calls IAC around 9:30 a.m.</p> <p>16270 kc. WLK -C- 18.44 meters LAWRENCEVILLE, N. J. Phonies Arg., Braz., Peru, daytime</p>	<p>16270 kc. WOG -C- 18.44 meters OCEAN GATE, N. J. Calls England, morning and early afternoon</p> <p>16240 kc. KTO -C- 18.47 meters MANILA, P. I. Calls Cal., Tokio and ships 8-11:30 a.m.</p> <p>16233 kc. FZR3 -C- 18.48 meters SAIGON, INDO-CHINA Calls Paris and Pacific Isles</p> <p>16030 kc. KKP -C- 18.71 meters KAHUKU, HAWAII Phonies KWU 3-10 p.m.</p> <p>15880 kc. FTK -C- 18.99 meters ST. ASSISE, FRANCE Phonies Saigon, morning</p> <p>15865 kc. CEC -C- 18.91 meters SANTIAGO, CHILE Works other S.A. stations afternoons</p> <p>15810 kc. LSL -C- 18.98 meters HURLINGHAM, ARGENTINA Calls Brazil and Europe, daytime</p> <p>15760 kc. JYT -X- 19.04 meters KEMIKWA-CHO, CHIBA- KEN, JAPAN Irregular in late afternoon and early morning</p> <p>15660 kc. JVE -C- 19.16 meters NAZAKI, JAPAN Phonies Java 3-5 a.m.</p> <p>15620 kc. JVF -C- 19.2 meters NAZAKI, JAPAN Phonies U.S., 5 a.m. & 4 p.m.</p> <p>15460 kc. KKR -C- 19.4 meters RCA COMMUNICATIONS, BOLINAS, CAL. Tests irregularly</p> <p>15450 kc. IUG -C- 19.41 meters ADDIS ABABA, ETHIOPIA Calls IAC 9:15-10:30 a.m.</p> <p>15415 kc. KWO -C- 19.48 meters DIXON, CAL. Phonies Hawaii 2-7 p.m.</p> <p>15370 kc. ★HAS3 -B- 19.52 meters BUDAPEST, HUNGARY Broadcasts Sundays, 9-10 a.m.</p> <p>15360 kc. DZG -X.C- 19.53 meters REICHSPOSTZENSTRALAMT, ZEESEN, GERMANY Tests irregularly</p> <p>15355 kc. KWU -C- 19.53 meters DIXON, CAL. Phonies Pacific Isles and Japan</p> <p>15340 kc. ★DJR -B- 19.56 meters BROADCASTING HOUSE, BERLIN, GERMANY 8-9 a.m.</p>
---	---	---	---	--

(All Schedules Eastern Standard Time)

15330kc. ★W2XAD

-B- 19.56 meters
GENERAL ELECTRIC CO.
SCHENECTADY, N. Y.
Relays
WGY 10 a.m.-4:30 p.m.

15310 kc. ★GSP

-B- 19.6 meters
DAVENTRY
B.B.C., BROADCASTING
HOUSE, LONDON, ENGLAND
6-8 p.m.

15290 kc. LRU

-B- 19.62 meters
"EL MUNDO"
BUENOS AIRES, ARGEN-
TINA, S. A.
Daily 7 a.m.-6:30 p.m.

15280 kc. ★DJQ

-B- 19.65 meters
BROADCASTING HOUSE
BERLIN, GERMANY
6-8, 8:15-11 a.m. also
Sundays 11:10 a.m.-12:20 p.m.

15270 kc. ★W2XE

-B- 19.65 meters
ATLANTIC BROADCASTING
CORP.,
485 Madison Bldg., N.Y.C.
Relays
WABC daily, 1-6 p.m.

15260 kc. GSI

-B- 19.66 meters
DAVENTRY.
B.B.C., BROADCASTING
HOUSE, LONDON, ENGLAND
12:15-3:45 p.m.

15252 kc. RIM

-C- 19.67 meters
TACHKENT, U.S.S.R.
Phones RKI near 7 a.m.

15250 kc. W1XAL

-B- 19.67 meters
BOSTON, MASS.
Irregular, in morning

15245 kc. ★TPA2

-B- 19.68 meters
"RADIO COLONIAL"
PARIS, FRANCE
Service de la Radiodiffusion
98, bis, Blvd. Hausmann
6-11:05 a.m.

15230 kc. HS8PJ

-B- 19.32 meters
BANGKOK, SIAM
Irregular, Mon. 8-10 a.m.

15230 kc. OLR

-B- 19.70 meters
PRAGUE
CZECHOSLOVAKIA
Irregular

15220 kc. ★PCJ

-B- 19.71 meters
N.V. PHILIPS' RADIO
EINDHOVEN, HOLLAND
Tues. 4:30-6 a.m.
Wed. 8-11 a.m.

15210 kc. ★W8XK

-B- 19.72 meters
WESTINGHOUSE ELECTRIC
& MFG. CO.
PITTSBURGH, PA.
9 a.m.-7 p.m.
Relays KDKA

15200 kc. ★DJB

-B- 19.74 meters
BROADCASTING HOUSE
BERLIN, GERMANY
12:05-5:15, 5:55-11 a.m.
Sun. also 11:10 a.m.-12:25 p.m.

15190 kc. ZBW4

-B- 19.75 meters
HONGKONG, CHINA
P. O. Box 200
11:30 p.m.-1:15 a.m., 4-10 p.m.

15180 kc. ★GSO

-B- 19.78 meters
DAVENTRY
B.B.C., BROADCASTING
HOUSE, LONDON, ENGLAND
2-4 a.m.

15180 kc. RW96

-B- 19.76 meters
MOSCOW, U.S.S.R.
Irregular

15160 kc. JZK

-B- 19.79 meters
TKDIO, JAPAN
2:30-3:30 p.m. Tues. and Fri.
Daily 12 m.-1 a.m., 4-5 p.m.

15150 kc. ★YDC

-B- 19.80 meters
NIRM
BANDENG, JAVA
6-7:30 p.m. 10:30 p.m.-2 a.m.
Sat. 7:30 p.m.-2 a.m. (Sun.)
5:30-10:30 a.m.

15140 kc. ★GSF

-B- 19.82 meters
DAVENTRY,
B.B.C., BROADCASTING
HOUSE, LONDON, ENGLAND
9 a.m.-12 n. 4-5:45; 9-11 p.m.

15120 kc. HVJ

-B- 19.83 meters
VATICAN CITY
10:30 to 10:45 a.m., except
Sunday
Sat. 10-10:45 a.m.

15110 kc. ★DJL

-B- 19.85 meters
BROADCASTING HOUSE,
BERLIN, GERMANY
12-2, 8-9 a.m., 11:35 a.m.-
4:30 p.m. Also 6-8 a.m., Sun.

15090 kc. RKI

-B, C- 19.88 meters
MOSCOW, U.S.S.R.
Phones Tashkent near 7 a.m.

15055 kc. WNC

-C- 19.92 meters
HIALEAH, FLORIDA
Calle Central America, daytime

14980 kc. KAY

-C- 20.03 meters
MANILA, P. I.
Phones Pacific Isles

14970 kc. LZA

-B, C- 20.04 meters
RADIO GARATA,
SOFIA, BULGARIA
Broadcasts Sun. 12:30-8 a.m.,
10 a.m.-4:30 p.m., Daily 5-6:30
a.m., 12 n-2:45 p.m.

14960 kc. PSF

-C- 20.43 meters
RIO DE JANEIRO, BRAZIL
Works with Buenos Aires
daytime

14950 kc. HJB

-C- 20.07 meters
BOGOTA, COL.
Calls WNC, daytime

14940 kc. HII

-C- 20.08 meters
CIUDAD TRUJILLO, D.R.
Phones WNC daytime

14940 kc. HJA3

-C- 20.08 meters
BARRANQUILLA, COL.
Works WNC daytime

14845 kc. OCJ2

-C- 20.21 meters
LIMA, PERU
Works other S.A. stations
daytime

14790 kc. ROU

-C- 20.28 meters
OMSK, SIBERIA, U.S.S.R.
Works Moscow Irregularly
7-9 a.m.

14730 kc. IQA

-C- 20.37 meters
ROME, ITALY
Tests Irregularly

14653 kc. GBL

-C- 20.47 meters
RUGBY, ENGLAND
Works JVB 1-7 a.m.

14640 kc. TYF

-C- 20.49 meters
PARIS, FRANCE
Works Saigon and Cairo 3-7
a.m., 12 n.-2:30 p.m.

14600 kc. JVH

-B, C- 20.55 meters
NAZAKI, JAPAN
Irregular 5-11:30 p.m.
Phones Europe 4-8 a.m.

14590 kc. WMN

-C- 20.56 meters
LAWRENCEVILLE, N. J.
Phones England
morning and afternoon

14535 kc. HBJ

-B- 20.64 meters
RADIO NATIONS,
GENEVA, SWITZERLAND
Broadcasts Irregularly

14530 kc. LSN

-C- 20.65 meters
HURLINGHAM, ARGENTINA
Calls N.Y.C. afternoons

14500 kc.

-C- 20.69 meters
ASMARA, ERITRIA, AFRICA
Works Rome and Addis Ababa
6:30-7:30 a.m.

14500 kc. LSM2

-C- 20.69 meters
HURLINGHAM, ARGENTINA
Calls Rio and Europe daytime

14485 kc. TIR

-C- 20.71 meters
CARTAGO, COSTA RICA
Phones Can. Amr. & U.S.A.
Daytime

14485 kc. YSJ

-C- 20.71 meters
SAN SALVADOR, SALVADOR
Phones WNC daytime

14485 kc. HPF

-C- 20.71 meters
PANAMA CITY, PAN.
Phones WNC daytime

14485 kc. TGF

-C- 20.71 meters
GUATEMALA CITY, GUAT.
Phones WNC daytime

14485 kc. YNA

-C- 20.71 meters
MANAGUA, NICARAGUA
Phones WNC daytime

14485 kc. HRL5

-C- 20.71 meters
NACAOME, HONDURAS
Works WNC daytime

14485 kc. HRF

-C- 20.71 meters
TEGUCIGALPA, HONOURAS
Works WNC daytime

14470 kc. WMF

-C- 20.73 meters
LAWRENCEVILLE, N. J.
Phones England in daytime

14460 kc. DZH

-C, X- 20.75 meters
REICHSPOSTZENSTRALMT,
ZEESEN, GERMANY
Irregular

14440 kc. GBW

-C- 20.78 meters
RUGBY, ENGLAND
Calls U.S.A., afternoons

14200 kc. EA9AH

-B- 21.13 meters
TETUAN, SPAIN, MOROCCO
Broadcasts daily except Sun.
2:15-5, 7 and 9 p.m.

13990 kc. GBA

-C- 21.44 meters
RUGBY, ENGLAND
Calls Buenos Aires, late afternoon

13980 kc. PZ1AA

-B- 21.46 meters
PARAMIRABO,
DUTCH GUIANA, S.A.
Irregular evenings.

13820 kc. SUZ

-C- 21.71 meters
ABOU ZABAL, EGYPT
Works with Europe 11 a.m.-2 p.m.

13690 kc. KKZ

-C- 21.91 meters
RCA COMMUNICATIONS,
BOLINAS, CAL.
Tests Irregularly

13635 kc. SPW

-B- 22 meters
WARSAW, POLAND
Mon., Wed., Fri. 12:30-1:30 p.m.
Irregular at other times

13610 kc. JYK

-C- 22.04 meters
KEMIKAWA-CHO, CHIBA-
KEN, JAPAN
Phones California till 11 p. m.

13585 kc. GBB

-C- 22.06 meters
RUGBY, ENGLAND
Calls Egypt & Canada, afternoon

13415 kc. GCJ

-C- 22.36 meters
RUGBY, ENGLAND
Calls Japan & China early
morning

13410 kc. YSJ

-C- 22.37 meters
SAN SALVADOR, SALVADOR
Phones WNC daytime

13390 kc. WMA

-C- 22.40 meters
LAWRENCEVILLE, N. J.
Phones England
morning and afternoon

13380 kc. IDU

-C, M- 22.42 meters
ASMARA, ERITREA, AFRICA
Works with Rome daytime

13345 kc. YVQ

-C- 22.48 meters
MARACAY, VENEZUELA
Calls Hialeah daytime

13285 kc. CGA3

-C- 22.58 meters
DRUMMONDVILLE, QUE..
CAN.
Works London and Ships
afternoons

13220 kc. IRJ

-C- 22.69 meters
ROME, ITALY
Phones Tokyo 5-9 a.m.
Irregularly

13075 kc. VPD

-X- 22.84 meters
SUVA, FIJI ISLANDS
Daily ex. Sun. 12:30-1:30 a.m.

12840 kc. WOO

-C- 23.36 meters
OCEAN GATE, N. J.
Calls ships

12825 kc. CNR

-B, C- 23.39 meters
DIRECTOR GENERAL
Telegraph and Telephone
Stations, Rabat, Morocco
Broadcasts, Sunday, 7:30-9 a. m.

12800 kc. IAC

-C- 23.45 meters
PISA, ITALY
Calle Italian ships, mornings

12780 kc. GBC

-C- 23.47 meters
RUGBY, ENGLAND
Calls ships

12396 kc. CT1GO

-B- 24.2 meters
PAREDE, PORTUGAL
Sun. 10-11:30 a.m., Tues.,
Thur., Fri. 1:00-2:15 p.m.

12325 kc. DAF

-C- 24.34 meters
NORDEICH, GERMANY
Works German ships daytime

12300 kc.

-B- 24.39 meters
SANTIAGO, CHILE, S.A.
Broadcasts evenings till 10 p.m.

12290 kc. GBU

-C- 24.41 meters
RUGBY, ENGLAND
Calls N.Y.C., afternoon

12250 kc. TYB

-C- 24.49 meters
PARIS, FRANCE
Irregular

12235 kc. ★TFJ

-B, C- 24.52 meters
REYKJAVIK, ICELAND
Phones England mornings,
Broadcasts Sun. 1:40-2:30 p.m.

12215 kc. TYA

-C- 24.56 meters
PARIS, FRANCE
Works French Ships in morning
and afternoon

12150 kc. GBS

-C- 24.68 meters
RUGBY ENGLAND
Calls N.Y.C., afternoon

12130 kc. DZE

-C, X- 24.73 meters
REICHSPOSTZENSTRALMT,
ZEESEN, GERMANY
Tests Irregularly

12120 kc.

-C- 24.75 meters
ALGIERS, ALGERIA
Calls Paris 12 m.-6:30 a.m.

12060 kc. PDV

-C- 24.88 meters
KOOTWIJK, HOLLAND
Tests Irregular

12000 kc. RNE

-B- 25 meters
MOSCOW, U. S. S. R.
Sun. 6-9, 10-11 a.m.
Wed. 6-7 a.m.

11991 kc. FZS2

-C- 25.02 meters
SAIGON, INDO-CHINA
Phones Paris, morning

11955 kc. IUC

-C- 25.09 meters
ADDIS ABABA, ETHIOPIA
Calls IAC around 12 m.

11950 kc. KKQ

-X- 25.10 meters
BOLINAS, CALIF.
Tests, Irregularly, evenings

11940 kc. FTA

-C- 25.13 meters
STE. ASSISE, FRANCE
Phones CNR morning,
Hurlingham, Arco., nights

11900 kc. XEWI

-B- 25.21 meters
MEXICO CITY, MEX.
Mon., Wed., Fri. 3-4 p.m.,
9 p.m.-12 m.
Tues., Thurs. 7:30 p.m.-12 m.
Sat. 9 p.m.-12 m.,
Sun. 12:30-2 p.m.

11880 kc. ★TPA3

-B- 25.23 meters
"RADIO COLONIAL"
PARIS, FRANCE
2-5 a.m., 11:15-6 p.m.

11875 kc. OLR

-B- 25.24 meters
PRAGUE, CZECHOSLOVAKIA
Irregular Mornings

11870 kc. ★W8XK

-B- 25.26 meters
WESTINGHOUSE ELECTRIC
& MFG. CO.
PITTSBURGH, PA.
7-10:30 p.m.
Relays KDKA

11860 kc. YDB

-B- 25.29 meters
N.I.R.O.M.,
SOERABAJA, JAVA
Sat. 7:30 p.m.-2 a.m. (Sun.)
Daily 10:30 p.m.-2 a.m.

11860 kc. GSE

-B- 25.29 meters
DAVENTRY,
B.B.C., BROADCASTING
HOUSE, LONDON, ENGLAND

11855 kc. DJP

-B, X- 25.31 meters
BROADCASTING HOUSE,
BERLIN, GERMANY
Irregular, 11:35 a.m.-4:30 p.m.

11830 kc. W9XAA

-B- 25.36 meters
CHICAGO FEDERATION OF
LABOR
CHICAGO, ILL.
Relays WCFL Irregular

11830 kc. ★W2XE

-B- 25.38 meters
ATLANTIC BROADCASTING
CORP.
485 MADISON AVE., N. Y. C.
Relays WABC 6-10 p.m.

11820 kc. GSN

-B- 25.38 meters
DAVENTRY
B.B.C., BROADCASTING
HOUSE, LONDON, ENGLAND
Irregular

11810 kc. ★2RO

-B- 25.4 meters
E.I.A.R.
Via Montello 5
ROME, ITALY
Daily 6:43-10:30, 11:30 a.m.-
12:40 p.m.; Sun.
6:43-9, 11:30 a.m.-12:40 p.m.

11800 kc. ★JZJ

-B- 25.42 meters
TKDIO, JAPAN
Daily 4-5 p.m.
Tues. and Fri. 2:30-3:30 p.m.
Daily 12 m.-1 a.m.; 9-10 a.m.

11800 kc. OER2

-B- 25.42 meters
VIENNA, AUSTRIA
Daily 10 a.m.-5 p.m.
Sat. till 5:30 p.m.

11795 kc. HP5-

-B- 25.43 meters
AGUADULCE, PANAMA
Broadcasts evenings irregularly

11795 kc. DJO

-B, X- 25.43 meters
BROADCASTING HOUSE,
BERLIN, GERMANY
Irregular

11790 kc. W1XAL

-B- 25.45 meters
BOSTON, MASS.
Daily 5:15-6:15 p.m.
Sun. 5-7 p.m.

11770 kc. ★DJD

-B- 25.49 meters
BROADCASTING HOUSE,
BERLIN, GERMANY
11:35 a.m.-4:30 p.m.; 4:50-
10:55 p.m.

11760 kc. OLR

-B- 25.51 meters
PRAGUE
CZECHOSLOVAKIA

11750 kc. ★GSD

-B- 25.53 meters
DAVENTRY,
B.B.C., BROADCASTING
HOUSE, LONDON, ENGLAND
12:15-5:45 p.m., 6-8, 9-11 p.m.

11730 kc

<p>11715 kc. ★TPA4 -B- 25.61 meters "RADIO COLONIAL" PARIS, FRANCE 6:15-8 p.m. 10 p.m.-1 a.m.</p>	<p>10535 kc. JIB -C- 28.48 meters TAIWAN, FORMOSA Phones around 6:25 a.m.</p>	<p>9950 kc. GCU -C- 30.15 meters RUGBY, ENGLAND Calls N.Y.C. evening</p>	<p>9635 kc. ★2RO -B- 31.13 meters E.I.A.R. ROME, ITALY Daily 12:40-5:30 p.m. Mon., Wed., Fri. 6-7:30 p.m. Tues., Thurs., Sat. 6-7:45 p.m.</p>	<p>9530 kc. ★W2XAF -B- 31.48 meters GENERAL ELECTRIC CO. SCHENECTADY, N. Y. Relays WGY 4 p.m.-12 m.</p>
<p>11710 kc. SM5SX -B- 25.63 meters STOCKHOLM, SWEDEN Daily 11 a.m.-5 p.m. Wed. till 6 p.m.</p>	<p>10520 kc. VLK -C- 28.51 meters SYDNEY, AUSTRALIA Calls Rugby, early a.m.</p>	<p>9930 kc. HKB -C- 30.21 meters BOGOTA, COL. Phones Rio de Janeiro evenings</p>	<p>9630 kc. HJ2ABD -B- 31.14 meters BUCARAMANGA, COL. 7-10 p.m. irregular</p>	<p>9525 kc. ZBW3 -B- 31.49 meters HONGKONG, CHINA P.O. BOX 200 11:30 p.m.-1:15 a.m., 4-10 a.m.</p>
<p>11680 kc. KIO -C, X- 25.68 meters KAHUKU, HAWAII Broadcasts Tues. 12:30-1 a.m. Irregular, Wed. 8-8:30 p.m. and Thurs. 9:30-10 p.m. Sat. 10- 10:30 p.m.</p>	<p>10430 kc. YBG -C- 28.76 meters MEDAN, SUMATRA 5:30-6:30 a. m., 7:30-8:30 p. m.</p>	<p>9930 kc. ★CSW -B- 30.21 meters NATL. BROAD. STATION LISBON, PORTUGAL 4-6 or 7 p.m.</p>	<p>9620 kc. HJ1ABP -B- 31.19 meters P.O. BOX 37, CARTAGENA, COL. 11 a.m.-1 p.m. 5-11 p.m. Sun. 10 a.m.-1 p.m., 3-6 p.m.</p>	<p>9525 kc. LKJ1 -B- 31.49 meters JELOY, NORWAY 5-8 a.m.</p>
<p>11600 kc. ★COCX -B- 25.86 meters HAVANA, CUBA Relays CMX 8 a.m.-1 a.m.</p>	<p>10420 kc. XGW -C- 28.79 meters SHANGHAI, CHINA Calls Japan 12 m.-3 a.m. and California late evening</p>	<p>9890 kc. LSN -C- 30.33 meters HURLINGHAM, ARGENTINA Calls New York, evenings</p>	<p>9615 kc. HP5J -B- 31.22 meters APARTADO 867, PANAMA CITY, PANAMA 12n-1:30 p.m., 6-10:30 p.m.</p>	<p>9520 kc. HJ4ABH -B- 31.51 meters ARMENIA, COLOMBIA Irregular 5 p.m.-12 m.</p>
<p>11595 kc. VRR4 -C- 25.87 meters STONY HILL, JAMAICA, B.W.I. Works WNC daytime.</p>	<p>10410 kc. PDK -C- 28.60 meters KDOTWIJK, HOLLAND Calls Java 7:30-9:40 a. m.</p>	<p>9870 kc. WON -C- 30.4 meters LAWRENCEVILLE, N. J. Phones England, evening</p>	<p>9600 kc. RAN -B- 31.25 meters MOSCOW, U.S.S.R. Daily 6-8 p.m.</p>	<p>9510 kc. ★VK3ME -B- 31.55 meters AMALGAMATED WIRELESS, LTD. 167 Queen St., MELBOURNE, AUSTRALIA Daily exe. Sun. 4-7 a.m.</p>
<p>11560 kc. VIZ3 -X- 25.95 meters AMALGAMATED WIRELESS OF AUSTRALASIA FISKVILLE, AUSTRALIA Calls Canada evening and early a.m.</p>	<p>10370 kc. EHZ -C, -B- 28.93 meters TENERIFFE, CANARY ISL. Relays EA143, 2-4, 6-7 or 9 p.m.</p>	<p>9840 kc. JYS -X- 30.49 meters KEMIKAWA-CHO, CHIBA- KEN, JAPAN Irregular, 11:30 p.m.-3 a.m.</p>	<p>9600 kc. CB960 -B- 31.25 meters SANTIAGO, CHILE 9:30 p.m. on</p>	<p>9510 kc. ★GSB -B- 31.55 meters DAVENTRY, B.B.C., BROADCASTING HOUSE, LONDON, ENGLAND 2-4 a.m., 12:15-5:45 p.m.</p>
<p>11500 kc. XAM -X- 26.09 meters MERIDA, YUCATAN Irregular 1-7:30 p.m.</p>	<p>10350 kc. LSX -C- 28.98 meters MONTE GRANDE, ARGENTINA Tests irregularly 8 p.m.-12 mid- night, Broadcasts Mon. and Fri. 5-6 p.m.</p>	<p>9830 kc. IRM -C- 30.52 meters ROME, ITALY Phones Egypt in the afternoon</p>	<p>9590 kc. ★PCJ -B- 31.28 meters N. V. PHILIPS RADIO EINDHOVEN, HOLLAND Sun. 2-3, 7-8 p.m. Tues. 1:30-3 p.m. Wed. 7-10 p.m.</p>	<p>9505 kc. ★HBL -B- 31.27 meters LEAGUE OF NATIONS GENEVA, SWITZERLAND Saturdays, 5:30-8:15 p. m. Mon. at 1:45 a.m.</p>
<p>11500 kc. PMK -B, -C- 26.09 meters BANDOENG, JAVA</p>	<p>10330 kc. ★ORK -B, -C- 29.04 meters RUYSELEDE, BELGIUM Broadcasts 2:30-4 p.m.</p>	<p>9800 kc. LSI -C- 30.61 meters MONTE GRANDE, ARGENTINA Tests irregularly</p>	<p>9590 kc. ★VK2ME -B- 31.28 meters AMALGAMATED WIRELESS, LTD. 47 YORK ST. SYDNEY, AUSTRALIA Sun. 1-3, 5-9, 9:30-11:30 a.m.</p>	<p>9505 kc. HJ1ABE -B- 31.57 meters P.O. BOX 31, CARTAGENA, COLOMBIA Daily 7:30-9 p.m., Mon. also 9:30-10:30 p.m.</p>
<p>11413 kc. CJA4 -C- 26.28 meters DRUMMONDVILLE, QUE., CAN. Tests with Australia irregularly in evening</p>	<p>10300 kc. LSL2 -C- 29.13 meters HURLINGHAM, ARGENTINA Calls Europe, evenings</p>	<p>9790 kc. GCW -C- 30.84 meters RUGBY, ENGLAND Calls N.Y.C., evening</p>	<p>9590 kc. ★W3XAU -B- 31.28 meters PHILADELPHIA PA. Relays WCAU Daily 12n-8 p.m.</p>	<p>9500 kc. HJU -B- 31.58 meters NATIONAL RAILWAYS BUENAVENTURA, COLOM- BIA Mon., Wed., Fri. 8-11 p.m.</p>
<p>11405 kc. HBO -X- 26:30 meters RADIO NATIONS GENEVA, SWITZERLAND Broadcasts irregularly</p>	<p>10290 kc. DZC -X- 29.16 meters REICHSPÖSTZENTRALAMPT, ZEESEN, GERMANY Broadcasts irregularly</p>	<p>9760 kc. VLJ-VLZ2 -C- 30.74 meters AMALGAMATED WIRELESS OF AUSTRALIA SYDNEY, AUSTRALIA Phones Java and N. Zealand early a.m.</p>	<p>9580 kc. ★W3XAU -B- 31.28 meters PHILADELPHIA PA. Relays WCAU Daily 12n-8 p.m.</p>	<p>9500 kc. PRF5 -B- 31.58 meters RIO DE JANEIRO BRAZIL Irregularly 4:45-5:45 p.m.</p>
<p>11280 kc. HIN -B- 26 meters LA VOZ DEL PARTIDO DOMINICANO, CIUDAD TRUJILLO, D.R. 4:40-5:40 p.m.</p>	<p>10260 kc. PMN -B, -C- 29.24 meters BANDOENG, JAVA Relays YDB 5:30-10:30 or 11 a.m.</p>	<p>9750 kc. WOF -C- 30.77 meters LAWRENCEVILLE, N. J. Phones England, evening</p>	<p>9580 kc. ★GSC -B- 31.32 meters DAVENTRY, B.B.C., BROADCASTING HOUSE, LONDON, ENGLAND 6-8, 9-11 p.m.</p>	<p>9490 kc. XEFT -B- 31.61 meters VERA CRUZ, MEXICO See 6120 kc.</p>
<p>11200 kc. XBJQ -X- 26.79 meters BOX 2825, MEXICO CITY, MEX. Irregular</p>	<p>10250 kc. LSK3 -C- 29.27 meters HURLINGHAM, ARGENTINA Calls Europe and U. S., after- noon and evening</p>	<p>9740 kc. ★COCQ -B- 30.78 meters HAVANA, CUBA 6:50 a.m.-1 a.m.</p>	<p>9570 kc. ★W1XK -B- 31.35 meters WESTINGHOUSE ELECTRIC & MFG. CO., SPRINGFIELD, MASS. Relays WBZ, 7 a.m.-1 a.m. Sun. 8 a.m.-1 a.m.</p>	<p>9480 kc. EAH -B- 31.65 meters MADRID, SPAIN 4-5 p.m.</p>
<p>11050 kc. ZLT4 -C- 27.15 meters WELLINGTON, N. ZEALAND Phones Australia and England early a.m.</p>	<p>10230 kc. CED -X- 29.33 meters ANTOFAGASTAN, CHILE Tests 7-9:30 p.m.</p>	<p>9710 kc. GCA -C- 30.89 meters RUGBY, ENGLAND Calls Argo. & Brazil, evenings</p>	<p>9570 kc. ★VK3LR -B- 31.34 meters CUCUTA, COL. 8 p.m.-12 n.</p>	<p>9470 kc. XEDQ -B- 31.68 meters GUADALAJARA, CALISEO, MEXICO Irregular</p>
<p>11000 kc. PLP -B, -C- 27.27 meters BANDOENG, JAVA Relays YDB 5:30-10:30 or 11 a.m., Sat. till 11:30 a.m.</p>	<p>10220 kc. PSH -C- 29.35 meters RIO DE JANEIRO, BRAZIL</p>	<p>9680 kc. ★CT1AA -B- 31 meters "RADIO COLONIAL" LISBON, PORTUGAL Tues., Thurs., Sat. 4-7 p.m.</p>	<p>9570 kc. ★W1XK -B- 31.35 meters WESTINGHOUSE ELECTRIC & MFG. CO., SPRINGFIELD, MASS. Relays WBZ, 7 a.m.-1 a.m. Sun. 8 a.m.-1 a.m.</p>	<p>9460 kc. ICK -C- 31.71 meters TRIPOLI, N. AFRICA Calls Rome 5:30-7 a.m.</p>
<p>10840 kc. KWV -C- 27.68 meters DIXON, CAL. Works with Hawaii evenings.</p>	<p>10170 kc. RIO -C- 29.5 meters BAKOU, U.S.S.R. Works with Moscow 10 p.m.-5 a.m.</p>	<p>9670 kc. TI4NRH -B- 31.02 meters AMANDO CEPEDAS MARIN, APARTADO 80, HEREDIA, COSTA RICA Daily 8:30-10, 11:30 p.m.-12 m.</p>	<p>9570 kc. ★W1XK -B- 31.35 meters WESTINGHOUSE ELECTRIC & MFG. CO., SPRINGFIELD, MASS. Relays WBZ, 7 a.m.-1 a.m. Sun. 8 a.m.-1 a.m.</p>	<p>9450 kc. TGWA -B- 31.75 meters MINISTRE DE FOMENTO GUATEMALA CITY, GUATEMALA Daily 11 a.m.-1 p.m. 8 p.m. 12m. Sat. 9 p.m.-5 a.m. (Sun).</p>
<p>10770 kc. GBP -C- 27.85 meters RUGBY, ENGLAND Calls Sydney, Austral. early a. m.</p>	<p>10140 kc. OPM -C- 29.59 meters LEOPOLDVILLE, BELGIAN CONGO Phones around 3 a.m. and 1- 4 p.m.</p>	<p>9660 kc. ★LRX -B- 31.06 meters "EL MUNDO" BUENOS AIRES, ARGENTINA 7-11:30 p.m. or 12 m.</p>	<p>9565 kc. VUB -B- 31.38 meters BOMBAY, INDIA 11:30 a.m.-12:30 p.m., Tues., Thurs., Fri.</p>	<p>9440 kc. HH2R -B- 31.78 meters FORT DE FRANCE, MARTINIQUE Irregular in evening</p>
<p>10740 kc. JVM -B, -C- 27.93 meters NAZAKI, JAPAN Phones U.S. 2-7 a.m. Broadcasting daily 9-10 a.m.</p>	<p>10080 kc. RIR -C- 29.76 meters TIFLIS, U.S.S.R. Works with Moscow early morning.</p>	<p>9650 kc. YDB -B- 31.09 meters SOERABAJA, JAVA N.I.R.O.M. Daily exe. Sat. 6-7:30 p.m., 5:30- 10:30 or 11 a.m., Sat. 5:30-11:30 a.m.</p>	<p>9560 kc. ★DJA -B- 31.38 meters BROADCASTING HOUSE, BERLIN 12:05-5:15 a.m., 5:55-11 a.m., 4:50-10:45 p.m.</p>	<p>9428 kc. ★COCH -B- 31.8 meters 2 B ST., VEDADO, HAVANA, CUBA Daily 7 a.m.-1 a.m.</p>
<p>10675 kc. WNB -C- 28.1 meters LAWRENCEVILLE, N. J. Calls Bermuda, daytime</p>	<p>10070 kc. EDM-EHY -C- 29.79 meters MADRID, SPAIN Works with S. America evenings</p>	<p>9645 kc. HH3W -B- 31.1 meters P.O. BOX A117, PORT-AU-PRINCE, HAITI 1-2, 7-8 p.m.</p>	<p>9555 kc. HJ1ABB -B- 31.36 meters BARRANQUILLA, COL., S.A. P. O. BOX 715 11:30 a.m.-1 p.m., 4:30-10 p.m.</p>	<p>9415 kc. PLV -C- 31.87 meters BANDOENG, JAVA Phones Holland around 9:45 a.m.</p>
<p>10670 kc. ★CEC -C- 28.12 meters SANTIAGO, CHILE Broadcasts Daily 7-7:15 p.m.</p>	<p>10055 kc. ZFB -C- 29.84 meters HAMILTON, BERMUDA Phones N. Y. C. daytime</p>	<p>9645 kc. YNLF -B- 31.1 meters MANAGUA, NICARAGUA 8-9 a.m., 12:30-2:30, 6:30- 10 p.m.</p>	<p>9550 kc. HJ1ABP -B- 31.19 meters P.O. BOX 37, CARTAGENA, COL. 11 a.m.-1 p.m. 5-11 p.m. Sun. 10 a.m.-1 p.m., 3-6 p.m.</p>	<p>9410 kc. ★DYN -B- 31.45 meters BROADCASTING HOUSE BERLIN, GERMANY 12:05-5:15 a.m., 4:50-10:45 p.m.</p>
<p>10660 kc. ★JVN -B, -C- 28.14 meters NAZAKI, JAPAN Broadcasts daily 2-8 a.m.</p>	<p>10042 kc. DZB -X- 29.87 meters ZEESEN, GERMANY Irregular</p>	<p>9645 kc. YNLF -B- 31.1 meters MANAGUA, NICARAGUA 8-9 a.m., 12:30-2:30, 6:30- 10 p.m.</p>	<p>9540 kc. ★DJN -B- 31.45 meters BROADCASTING HOUSE BERLIN, GERMANY 12:05-5:15 a.m., 4:50-10:45 p.m.</p>	<p>9400 kc. ★WNA -C- 32.72 meters LAWRENCEVILLE, N. J. Phones England, evening</p>
<p>10550 kc. WOK -C- 28.44 meters LAWRENCEVILLE, N. J. Phones Arge., Braz., Peru. nights</p>	<p>9990 kc. KAZ -C- 30.03 meters MANILLA, P.I. Works with Java, Cal. and ships early morning</p>	<p>9645 kc. YNLF -B- 31.1 meters MANAGUA, NICARAGUA 8-9 a.m., 12:30-2:30, 6:30- 10 p.m.</p>	<p>9540 kc. VPD2 -B- 31.45 meters SUVA, FIJI ISLANDS AMALGAMATED WIRELESS OF AUSTRALASIA Daily except Sun. 5:30-7 a.m.</p>	<p>9350 kc. HS8PJ -B- 32.09 meters BANGKOK, SIAM Thur. 8-10 a.m.</p>

(All Schedules Eastern Standard Time)

9125 kc. ★HAT4
-B- 32.88 meters
"RADIOLABOR,"
GYALI-UT, 22
BUDAPEST, HUNGARY
Sunday 6-7 p.m.

9060 kc. TFK
-B- 33.11 meters
REYKJAVIK, ICELAND
Phones London afternoons.
Broadcasts irregularly.

9020 kc. GCS
-C- 33.28 meters
RUGBY, ENGLAND
Calls N.Y.C., evenings

9010 kc. KEJ
-C- 33.3 meters
BDLINAS, CAL.
Relays NBC & CBS
Programs in evening irregularly

8975 kc. VWY
-C- 33.43 meters
KIRKEE, INDIA
Works with England in morning

8960 kc.
-C- 33.48 meters
ALGIERS, ALGERIA
Calls Paris

8950 kc. HCJB
-B- 33.5 meters
QUITO, ECUADOR
7:30-9:30 p.m., except Monday
Sun. 11 a.m.-12 n.; 4-10 p.m.

8795 kc. HKV
-B- 34.09 meters
BOGOTA, COLOMBIA
Mon. and Thurs. 7-7:30 p.m.

8775 kc. PNI
-C- 34.19 meters
MAKASSER, CELEBES,
N.I.
Phones Java around 4 a. m.

8765 kc. DAF
-C- 34.23 meters
NORDDEICH, GERMANY
Works German Ships irregularly

8760 kc. GCQ
-C- 34.25 meters
RUGBY, ENGLAND
Calls S. Africa, afternoon

8750 kc. FZE8
-C- 34.29 meters
DJBOUTI, FR. SOMALILAND
AFRICA
Calls Paris around 2:30 a.m.

8730 kc. GCI
-C- 34.36 meters
RUGBY, ENGLAND
Calls India, 8 a. m.

8680 kc. GBC
-C- 34.56 meters
RUGBY, ENGLAND
Calls ships

8665 kc. CO9JQ
-X- 34.62 meters
4 GENERAL GOMEZ
CAMAGUEY, CUBA
5:30-6:30, 8-9 p.m., daily
except Sat. and Sun.

8590 kc. YNVA
-B- 34.92 meters
MANAGUA, NICARAGUA
7:30-9:30 p. m.

8560 kc. WOO
-C- 35.05 meters
OCEAN GATE, N. J.
Calls ships irregular

8400 kc. HC2CW
-B- 35.71 meters
GUAYAQUIL, ECUADOR
11:30 a.m.-12:30 p.m., 8-11 p.m.

8380 kc. IAC
-C- 35.8 meters
Pisa, Italy

8190 kc. XEME
-B- 36.63 meters
CALLE 59, No. 517
MERIDA, YUCATAN
"LA VOZ de YUCATAN desde
MERIDA"
10 a.m.-12 n., 6 p.m.-12 m.

8185 kc. PSK
-C- 36.65 meters
RIO DE JANEIRO, BRAZIL
Irregularly

8036 kc. CNR
-B- 37.33 meters
RABAT, MOROCCO
Sunday, 2:30-5 p. m.

7975 kc. HC2TC
-B- 37.62 meters
QUITO, ECUADOR
Thurs., Sun. at 8 p.m.

7901 kc. LSL
-C- 37.87 meters
HURLINGHAM, ARGENTINA
Calls Brazil, night

7880 kc. JYR
-B- 38.07 meters
KEMIKAWA-CHO, CHIBA-
KEN, JAPAN
4-7:40 a. m.

7860 kc. SUX
-C- 38.17 meters
ABOU ZABAL, EGYPT
Works with Europe 4-6 p.m.

7854 kc. HC2JSB
-B- 38.2 meters
GUAYAQUIL, ECUADOR
Evenings

7799 kc. ★HBP
-B- 38.47 meters
LEAGUE OF NATIONS,
GENEVA, SWITZERLAND
5:30-6:15 p. m., Saturday

7715 kc. KEE
-C- 38.89 meters
BDLINAS, CAL.
Relays NBC & CBS
Programs in evening irregularly

7626 kc. RIM
-C- 39.34 meters
TACHKENT, U.S.S.R.
Works with Moscow early
morning

7610 kc. KWX
-C- 39.42 meters
DIXON, CAL.
Works with Hawaii, Philip-
pines, Java and Japan nights.

7550 kc. TI8WS
-B- 39.74 meters
"ECOS DEL PACIFIC"
P. O. BOX 75 PUNTA
ARENAS, COSTA RICA
6 p.m.-12 m.

7520 kc. KKH
-C- 39.89 meters
KAHUKU, HAWAII
Works with Dixon and broad-
casts irregularly nights

7510 kc. JVP
-B.C- 39.95 meters
NAZAKI, JAPAN

7500 kc. RKI
-C- 40 meters
MOSCOW, U.S.S.R.
Works RIM early a.m.

7390 kc. ZLT2
-C- 40.6 meters
WELLINGTON, N.Z.
Works with Sydney 3-7 a.m.

7380 kc. XECR
-B- 40.65 meters
FOREIGN OFFICE,
MEXICO CITY, MEX.
Sun. 6-7 p.m.

7281 kc. HJ1ABD
-B- 41.04 meters
CARTAGENA, COLO.
Irregularly, evenings

7100 kc. FO8AA
-B- 42.25 meters
PAPEETE, TAHITI
Tues. and Fri. 11 p.m.-12 m.

7100 kc. HKE
-B- 42.25 meters
BOGOTA, COL., S. A.
Tues. and Sat. 8-9 p. m.; Mon.
& Thurs. 6:30-7 p. m.

7074 kc. HJ1ABK
-B- 42.69 meters
CALLE, BOLIVIA,
PROGRESO-IGUALDAD
BARRANQUILLA, COLOMBIA
Sun. 3-6 p.m.

7030 kc. HRP1
-B- 42.67 meters
SAN PEDRO SULA,
HONDURAS
Reported on this and other waves
irregularly in evening

6996 kc. PZH
-B- 42.88 meters
P. O. BOX 18,
PARAMIRABO, DUTCH
GUIANA
Daily 6:06-8:36 a.m.
Sun. 9:36-11:36 a.m.
Daily 5:36-8:36 p.m.

6977 kc. XBA
-B- 43 meters
TACUBAYA, D.F., MEX.
9:30 a.m.-1 p.m., 7-8:30 p.m.

6976 kc. HC2TC
-B- 43 meters
TEATRO BOLIVAR
QUITO, ECUADOR
Thurs. till 9:30 p.m.

6905 kc. GDS
-C- 43.45 meters
RUGBY, ENGLAND
Calls N.Y.C. evening

6860 kc. KEL
-X- 43.70 meters
BOLINAS, CALIF.
Tests irregularly
11 a. m.-12 n.; 6-9 p. m.

6850 kc. TI60W
-B- 43.8 meters
ONDAS del CARIBE
PUERTO RICO, COSTA
RICA
Daily 12 n.-1:30 p.m.

6850 kc. XGOX
-B- 43.8 meters
NANKING, CHINA
Daily 6:40-8:40 a.m.
Sun. 4:40-6:05 a.m.

6800 kc. HI7P
-B- 44.12 meters
EMISORIA DIARIA de COM-
ERCIO, CIUDAD TRUJILLO,
DOM. REP.
Daily exc. Sat. and Sun. 12:40-
1:40, 6:40-8:40 p.m.; Sat. 12:40-
1:40 p.m.; Sun. 10:40 a.m.-
11:40 a. m.

6770 kc. HIH
-B- 44.26 meters
SAN PEDRO de MACDRIS
DOMINICAN REP.
12:10-1:40 p.m., 7:30-9 p.m.,
Sun. 3-4 a.m., 4:15-6 p.m.
p.m.; 4:40-7:40 p.m.

6755 kc. WOA
-C- 44.41 meters
LAWRENCEVILLE, N. J.
Phones England, evening

6750 kc. JVT
-B.C- 44.44 meters
NAZAKI, JAPAN
KDKUBAI-DENWA KAISHA,
LTD., TOKIO

6730 kc. HI3C
-B- 44.58 meters
"LA VOZ DE LA FERIA"
LA ROMANA, DOM. REP.
12:30-2 p.m. 5-6 p.m.

6720 kc. PMH
-B.C- 44.64 meters
BANDONC, JAVA
Relays NIROM programs
5:30-10:30 or 11 a.m.

6710 kc. ★TIEP
-B- 44.71 meters
LAVOZ DEL TROPICO
SAN JOSE, COSTA RICA
APARTADO 257, Daily 7-10
p.m.

6672 kc. YVQ
-C- 44.85 meters
MARACAY, VENEZUELA
Broadcasts Sat. 8-9 p.m.

6650 kc. IAC
-C- 45.11 meters
PISA, ITALY
Calls ships, evenings

6635 kc. ★HC2RL
-B- 45.21 meters
P. O. BOX 759, GUAYAQUIL,
ECUADOR, S. A.
Sunday, 5:45-7:45 p. m.
Tues., 8:15-11:15 p. m.

6630 kc. HIT
-B- 45.25 meters
"LA VOZ DE LA RCA VICTOR,"
APARTADO 1105, CIUDAD
TRUJILLO, D.R.
Daily exc. Sun. 12:10-1:40 p.m.,
5:40-8:40 p.m., also Sat. 10:40
p.m.-12:40 a.m. (Sun.)

6625 kc. ★PRADO
-B- 45.28 meters
RIOBAMBA, ECUADOR
Thurs. 8-11:45 p.m.

6558 kc. HI4D
-B- 45.74 meters
CIUDAD TRUJILLO, DOM-
INICAN REPUBLIC
Except Sun. 11:55 a.m.-1:40
p.m.

6550 kc. XBC
-B- 45.8 meters
VERA CRUZ, MEX.
8:15-9 a.m.

6550 kc. TIRCC
-B- 45.8 meters
RADIOEMISORA CATOLICA
COSTARRICENSE
SAN JOSE, COSTA RICA
Sun. 11 a.m.-2 p.m., 6-7, 8-9
p.m., Daily 12 n.-2 p.m., 6-7
p.m., Thurs. 6-11 p.m.

6545 kc. YV—
-B- 45.84 meters
"ECOS de ORINOCO",
BOLIVAR, VENEZUELA
6-10:30 p.m.

6520 kc. ★YV4RB
-B- 46.01 meters
VALENCIA, VENEZUELA
11 a.m.-2 p.m., 5-10 p.m.

6500 kc. HIL
-B- 46.15 meters
APARTADO 623
CIUDAD TRUJILLO, D.R.
12:10-1:40 p.m., 5:40-
7:40 p.m.

6477 kc. HI4V
-B- 46.32 meters
CIUDAD TRUJILLO, D.R.
LA VOZ de LA MARINA
11:40 a.m.-1:40 p.m., 5:10-9:40
p.m.

6450 kc. HJ4ABC
-B- 46.51 meters
APARTADO 39
IBAQUE, COLOMBIA
11 a.m.-12 n., 8-11 p.m.

6450 kc. HI8A
-B- 46.51 meters
CIUDAD TRUJILLO, DOM. REP.
8:40-10:40 a.m., 2:40-4:10 p.m.,
Sat. 9:40-10:40 p.m., Sun 2:40-
4:40 p.m.

6425 kc. W9XBS
-X- 46.7 meters
NATL. BROAD. CO.
CHICAGO, ILL.
Relays WMAQ, Irregular

6420 kc. HI1S
-B- 46.73 meters
PUERTO PLATA, DOM. REP.
11:40 a.m.-1:40 p.m., 5:40-
7:40, 9:40-11:40 p.m.

6410 kc. TIPG
-B- 46.8 meters
APARTADO 225,
SAN JOSE, COSTA RICA
"LA VOZ DE LA VICTOR"
12 n.-2 p.m., 6-11:30 p.m.

6400 kc. YV5RH
-B- 46.88 meters
CARACAS, VENEZUELA
7-11 p.m.

6355 kc. YV1RH
-B- 47.2 meters
"ONDAS DEL LAGO,"
MARACAIBO, VENEZUELA
8-11 p.m.

6350 kc. YV1RG
-B- 47.21 meters
VALERA, VENEZUELA
5:30-6:30 p.m.

6316 kc. HIZ
-B- 47.5 meters
CIUDAD TRUJILLO
DOMINICAN REPUBLIC
Daily except Sat. and Sun.
11:10 a.m.-2:25 p.m., 5:10-8:40
p.m.; Sat. 5:10-11:10 p.m.;
Sun., 11:40 a.m.-1:40 p.m.

6300 kc. YV4RG
-B- 47.62 meters
MARACAY, VENEZUELA
8-10:30 p.m.

6290 kc. YV5RP
-B- 47.69 meters
CARACAS, VEN.
LA VOZ DE LA PHILCO
Irregular

6282 kc. COHB
-B- 47.76 meters
P.O. BOX 85,
SANCTI SPIRITUS, CUBA
4-6, 9-11 p.m.

6280 kc. HIG
-B- 47.77 meters
CIUDAD TRUJILLO, D.R.
7:10-8:40 a.m., 12:40-2:10,
8:10-9:40 p.m.

6243 kc. HIN
-B- 48 meters
CIUDAD TRUJILLO, D.R.
LA VOZ DEL PARTIDO
DOMINICANO
12 n.-2 p.m., 7:30-9:30 p.m.

6235 kc. HRD
-B- 48.12 meters
LA VOZ DE ATLANTIDA
LA CEIBA, HONDURAS
8-11 p.m., Sat. 8 p.m.-1 a.m.
(Sun.); Sun. 4-6 p.m.

6230 kc. OAX4G
-B- 48.15 meters
Apartado 1242
LIMA, PERU
Daily 7-10:30 p.m.

6185 kc. HI1A
-B- 48.5 meters
P. D. BOX 423, SANTIAGO,
DOMINICAN REP.
11:40 a. m.-1:40 p. m.
7:40-9:40 p. m.
Wed. 6-10:30 p.m.

6171 kc. XEXA
-B- 48.61 meters
DEPT. OF EDUCATION
MEXICO CITY, MEX.
7-11 p.m.

6170 kc. HJ3ABF
-B- 48.62 meters
BOGOTA, COLOMBIA
7-11:15 p. m.

6160 kc. ★YV5RD
-B- 48.7 meters
CARACAS, VENEZUELA
11 a.m.-2 p.m., 4-10:30 p.m.

6150 kc. CSL
-B- 48.78 meters
LISBON, PORTUGAL
Irregular
7-8:30 a.m., 2-7 p.m.

6150 kc. ★CJRO
-B- 48.78 meters
WINNIPEG, MAN., CANADA
8 p. m.-12 m.
Sun. 3-10:30 p. m.

6147 kc. COKG
-B- 48.8 meters
BOX 137, SANTIAGO, CUBA
9-10 a.m., 11 a.m.-1:30 p.m.,
3-4:30 p.m., 10-11 p.m., 12 m.-
2 a.m.

6145 kc. HJ4ABU
-B- 48.8 meters
PEREIRA, COL.
9-11 a.m., 7-8 p.m.

6140 kc. ★W8XK
-B- 48.86 meters
WESTINGHOUSE ELECTRIC
& MFG. CO.
PITTSBURGH, PA.
Relays KOKA
9 p.m.-1 a.m.

6135 kc. HJ1ABB
-B- 48.9 meters
BARRANQUILLA, COL., S. A.
P. O. BOX 715,
11:30 a.m.-1 p.m.; 4:30-10 p.m.

6135 kc. ★HI5N
-B- 48.9 meters
SANTIAGO, D.R.
6:40-9:10 p.m.

6132 kc. HIX
-B- 48.93 meters
CIUDAD TRUJILLO,
DOMINICAN REP.
Sun. 7:40-10:10; Daily 12:40-
1:10 p.m., 4:40-5:40 p.m.;
Tues. and Fri. 8:10-10:10 p.m.

6130 kc. TGXA
-B- 48.94 meters
GIORNAL LIBERAL PRO-
GRESSISTA, GAUTEMALA
CITY, GUAT.
Heard in the evening.

6130 kc. COCD
-B- 48.94 meters
"LA VOZ DEL AIRE"
CALLE 25, VEDADO,
HAVANA, CUBA
Relays CMCD 11 a.m.-12 n., 7-
10 p.m., Sun. 12 n.-4 p.m.

6130 kc. ZGE
-B- 48.94 meters
KUALA LUMPUR,
FED. MALAY STATES
Sun., Tues. and Fri.,
6:40-8:40 a. m.

6130 kc. ★VE9HX
-B- 48.94 meters
P.O. BOX 988
HALIFAX, N.S., CANADA
Mon.-Fri., 9 a.m.-1 p.m.,
5-11 p.m.
Fri. 1-3 p.m.; Sat., Sun. 9 a.m.-
1 p.m., 2-11 p.m.
Relays CHNS

6122 kc. HJ3ABX
-B- 49 meters
LA VOZ de COLOMBIA
Apartado 2663
BOGOTA, COLOMBIA
Daily 10:30 a.m.-2 p.m., 5:30-
11 a.m., Sun. 6-11 p.m.

6120 kc. ★W2XE
-B- 49.02 meters
ATLANTIC BROADCASTING
CORP.
485 MADISON AVE., N. Y. C.
Relays WABC, 11 p.m.-12 m.

6120 kc. XEFT
-B- 49.02 meters
AV. INDEPENDENCIA 28,
VERA CRUZ, MEX.
11 a.m.-4 p.m., 7:30 p.m.-12 m.
Sat. also 6:30-7:30 p.m.
Sun. 11 a.m.-4 p.m., 9 p.m.-12
m. Relays XETF

6115 kc. OLR
-B- 49.05 meters
PRAGUE
CZECHOSLOVAKIA
Irregular

6110 kc. ★GSL
-B- 49.1 meters
DAVENTRY
B. B. C. BROADCASTING
HOUSE, LONDON, ENGLAND
Irregular

6110 kc. VUC
-B- 49.1 meters
CALCUTTA, INDIA
Daily 3-5:30 a.m., 9:30 a.m.-
noon, Sun. 7:30 a.m.-12n.

6105 kc. HJ4ABB
-B- 49.14 meters
MANIZALES, COL., S. A.
P. O. BOX 175
Mon. to Fri. 12:15-1 p. m.;
Tues. & Fri. 7:30-10 p. m.;
Sun. 2:30-5 p. m.

(All Schedules Eastern Standard Time)

<p>6100 kc. ★W3XAL -B- 49.18 meters NATIONAL BROADCASTING CO. BOUND BROOK, N. J. Relays WJZ Monday, Wednesday, Saturday, 5-6 p.m., Sun. 12 m.-1 a.m.</p> <p>6100 kc. ★W9XF -B- 49.18 meters NATL. BROAD. CO. CHICAGO, ILL. Tues., Thurs., Fri. 12 m.-1 a.m., 8 p.m.-11:30 p.m., M., W. Sat. 12 m.-1 a.m. Relays WENR</p> <p>6097 kc. ZTJ -B- 49.2 meters AFRICAN BROADCASTING CO. JOHANNESBURG, SOUTH AFRICA. Sun.-Fri. 11:45 p.m. 12:30 a.m. (next day) Mon.-Sat. 5:30-7 a.m. 9 a.m.-4 p.m. Sun. 8-10:15 a.m.; 12:30-3 p.m.</p> <p>6095 kc. JZH -B- 49.22 meters TOKIO, JAPAN Irregular</p> <p>6092 kc. HJ4ABE -B- 49.25 meters MEDELLIN, COLO. Daily 11 a.m.-12 n., 6-10:30 p.m.</p> <p>6090 kc. ★CRCX -B- 49.26 meters TORONTO, CANADA Daily 5:30-11:30 p.m. Sun. 5-11:30 p.m.</p> <p>6090 kc. VE9BJ -B- 49.28 meters SAINT JOHN, N. B., CAN. 7-8:30 p. m.</p> <p>6090 kc. ZBW2 -B- 49.26 meters P. O. BOX 200 HONGKONG, CHINA Irregular 11:30 p.m.-1:15 a.m., 4-10 a.m.</p> <p>6085 kc. HJ5ABD -B- 49.3 meters "LA VOZ de VALLE" CALI, COLOMBIA 12 n.-1:30 p.m., 5:10-9:40 p.m.</p> <p>6083 kc. VQ7LO -B- 49.31 meters NAIROBI, KENYA, AFRICA Mon.-Fri. 5:45-6:15 a.m., 11:30 a.m.-2:30 p.m. Also 8:30-9:30 a.m. on Tues. and Thurs.; Sat. 11:30 a.m.-3:30 p.m.; Sun. 11 a.m.-2 p.m.</p> <p>6080 kc. ZHJ -B- 49.34 meters PENANG, MALAYA Daily exc. Sun. 8:40-8:40 a.m. also Sat. 11 p.m.-1 A.M. (Sun.)</p> <p>6080 kc. CP5 -B- 49.34 meters LAPAZ, BOLIVIA 7-10:30 p. m.</p> <p>6080 kc. HP5F -B- 49.34 meters CARLTON HOTEL COLON, PANAMA 11:45 a.m.-1:15 p.m., 7:45-10 p.m.</p> <p>6080 kc. W9XAA -B- 49.34 meters CHICAGO FEDERATION OF LABOR CHICAGO, ILL. Relays WCFL Sunday 11:30 a. m.-9 p. m. and Tues., Thurs., Sat., 4 p. m.-12 m.</p> <p>6079 kc. DJM -B-X- 49.34 meters BROADCASTING HOUSE. BERLIN, GERMANY</p>	<p>6070 kc. YV1RD -B- 49.42 meters MARACAIBO, VENEZUELA 6-11 p.m.</p> <p>6070 kc. HJ4ABC -B- 49.42 meters PERIERA, COL. 9-11 a.m., 7-8 or 9 p. m.</p> <p>6070 kc. VE9CS -B- 49.42 meters VANCOUVER, B. C., CANADA Sun. 1:45-9 p. m., 10:30 p. m.-1 a. m.; Tues. 6-7:30 p. m., 11:30 p. m.-1:30 a. m., Daily 6-7:30 p. m.</p> <p>6065 kc. HJ4ABL -B- 49.46 meters MANIZALES, COL. Daily 11 a.m.-12 n., 5:30-7:30 p.m. Sat. 5:30-10:30 p.m.</p> <p>6060 kc. ★W8XAL -B- 49.50 meters CROSLY RADIO CORP. CINCINNATI, OHIO 5:30 a.m.-8 p.m.; 11 p.m.-1 a.m. Relays WLW</p> <p>6060 kc. W3XAU -B- 49.50 meters PHILADELPHIA, PA. Relays WCAU 8 p.m.-11 p.m.</p> <p>6060 kc. OXY -B- 49.50 meters SKAMLEBOEK, DENMARK 1-6:30 p.m.</p> <p>6050 kc. GSA -B- 49.59 meters DAVENTRY B. B. C. BROADCASTING HOUSE, LONDON, ENGLAND Irregular</p> <p>6050 kc. HJ3ABD -B- 49.59 meters COLOMBIA BROADCASTING BOX 509, BOGOTA, COL. 12 n.-2 p.m., 7-11 p.m., Sun. 5-9 p.m.</p> <p>6045 kc. HI9B -B- 49.63 meters SANTIAGO DOM. REP. Irregular 6 p.m.-11 p.m.</p> <p>6042 kc. HJ1ABG -B- 49.65 meters EMISORA ATLANTICO BARRANQUILLA, COLO. 11 a.m.-11 p.m. Sun. 11 a.m.-8 p.m.</p> <p>6040 kc. W4XB -B- 49.67 meters MIAMI BEACH, FLA. Relays WIDD 12 n.-2 p.m., 5:30 p.m.-12 m.</p> <p>6040 kc. ★W1XAL -B- 49.67 meters BOSTON, MASS. Tues., Thurs. 7:15-9:15 p.m. Sun 5-7 p.m.</p> <p>6040 kc. YDA -B- 49.67 meters N. I. R. O. M. TANDJONGPRAK, JAVA 10:30 p.m.-2 a.m. Sat. 7:30 p.m., 2 a.m. (Sun.)</p> <p>6030 kc. HJ4ABP -B- 49.75 meters MEDELLIN, COL. Relays HJ4ABQ 8-11 p.m.</p> <p>6030 kc. ★HP5B -B- 49.75 meters P. O. BOX 910 PANAMA CITY, PAN. 12 n.-1 p.m., 7-10:30 p.m.</p> <p>6030 kc. VE9CA -B- 49.75 meters CALGARY, ALBERTA, CAN. Thurs. 9 a.m.-2 a.m. (Fri.); Sun. 12 n.-12 m. Irregularly on other days from 9 a.m.-12 m.</p>	<p>6030 kc. ★OLR -B- 49.75 meters PRAGUE, CZECHOSLOVAKIA Daily 2:45-4:30 p.m.</p> <p>6025 kc. HJ1ABJ -B- 49.79 meters SANTA MARTA, COLO. 5:30-10:30 p.m. except Wed.</p> <p>6020 kc. ★DJC -B- 49.83 meters BROADCASTING HOUSE, BERLIN 11:35 a.m.-4:30 p.m.,</p> <p>6020 kc. XEUW -B- 49.82 meters AV. INDEPENDENCIA, 98, VERA CRUZ, MEX. 6 p.m.-12:30 a.m.</p> <p>6018 kc. ZHI -B- 49.85 meters RADIO SERVICE CO., 20 ORCHARD RD., SINGAPORE, MALAYA Mon., Wed. and Thurs 5:40-9:10 a.m. Sat. 10:40 p.m.-1:10 a.m. (Sun.) Every other Sunday 5:10-6:40 a.m.</p> <p>6015 kc. HI3U -B- 49.88 meters SANTIAGO de los CABALLEROS, DOM. REP. 7:30-9 a.m., 12 n.-2 p.m., 5-7 p.m., 8-9:30 p.m., Sun. 12:30-2, 5.6 p.m.</p> <p>6012 kc. HJ3ABH -B- 49.91 meters BOGOTA, COLO. APARTADO 565 6-11 p.m. Sun. 12 n.-2 p.m., 4-11 p.m.</p> <p>6010 kc. VP3MR -B- 49.9 meters GEORGETOWN, BRI. GUIANA, S.A. Sun. 7:45-10:15 a.m. Daily 4:45-8:45 p.m.</p> <p>6010 kc. ★COCO -B- 49.92 meters P.O. BOX 98 HAVANA, CUBA Daily 9:30 a.m.-1 p.m., 4-7 p.m., 8-10 p.m. Sat. also 11:30 p.m.-2 a.m.</p> <p>6005 kc. HP5K -B- 49.95 meters BOX 33, COLON, PANAMA 7:30-9 a.m., 12 n.-1 p.m., 8-9 p.m.</p> <p>6005 kc. ★CFCX -B- 49.96 meters CANADIAN MARCONI CO., MONTREAL, QUE., CAN. Relays CFCF 6 a.m.-11:15 p.m. Sun. 9 a.m.-11:15 p.m.</p> <p>6000 kc. HJ1ABC -B- 50 meters QUIBDO, COLOMBIA 5-6 p.m., Sun. 9-11 p.m.</p> <p>6000 kc. RV59 -B- 50 meters MOSCOW, U.S.S.R. Daily 12:30-6 p.m.</p> <p>5990 kc. ★XEBT -B- 50.00 meters MEXICO CITY, MEX. P. O. Box 78-44 8 a.m.-1 a.m.</p> <p>5988 kc. HJ2ABD -B- 50.10 meters BUARAMANGA, COL. 11:30 a.m.-12:30 p.m., 6:30-8:30, 7:30-10:30 p.m.</p> <p>5968 kc. HVJ -B- 50.27 meters VATICAN CITY 2-2:15 p. m., daily, Sun., 5-5:30 a. m.</p>	<p>5950 kc. HJN -B- 50.42 meters BOGOTA, COL. 8-11 p.m.</p> <p>5940 kc. TG2X -B- 50.5 meters GUATEMALA CITY, GUAT. 4-6, 9-11 p.m., Sun. 2-5 a.m.</p> <p>5930 kc. HJ4ABD -B- 50.51 meters LA VOZ CATIA, MEDELLIN, COLOMBIA 8-11:30 p.m.</p> <p>5915 kc. HH2S -B- 50.72 meters PORT AU PRINCE, HAITI BOX A103. 7-9:45 p.m.</p> <p>5910 kc. YV4- -B- 50.76 meters MARACAY, VENEZUELA Irregular</p> <p>5898 kc. YV3RB -B- 50.86 meters "LA VOZ de LARA" BARQUISIMETO, VENEZUELA 12 n.-1 p.m., 6-10 p.m.</p> <p>5890 kc. JIC -C- 50.93 meters TAIHOUI, FORMOSA Phones Tokyo 6-9 a.m.</p> <p>5885 kc. HCK -B- 50.98 meters QUITO, ECUADOR, S. A. 8-11 p.m.</p> <p>5875 kc. HRN -B- 51.06 meters TEGUCIGALPA, HONDURAS 1:15-2:15, 8:30-10 p.m., Sun. 3:30-5:30, 8:30-9:30 p.m.</p> <p>5865 kc. HI1J -B- 51.15 meters BOX 204, SAN PEORO de MACORIS, DOM. REP. 12 a.-2, 6:30-9 p.m.</p> <p>5853 kc. WOB -C- 51.26 meters LAWRENCEVILLE, N. J. Calls Bermuda, nights</p> <p>5850 kc. ★YV1RB -B- 51.28 meters CALLE REGISTRADO, LAS DELICIAS APARTADO de CDR. RES 214 MARACAIBO, VENEZUELA 8:45-9:45 a.m., 11:15 a.m.-12:15 p.m., 4:45-9:45 p.m. Sun. 11:45 a.m.-12:45 p.m.</p> <p>5830 kc. TDD -C- 51.46 meters SHINKYO, MANCHUKUO Phones Tokyo 6-9 a.m.</p> <p>5830 kc. ★TIGPH -B- 51.5 meters ALMA TICA, APARTADO 800, SAN JOSE, COSTA RICA 11 a.m.-1 p.m., 6-10 p.m., Relays TIX 9-10 p.m.</p> <p>5800 kc. ★YV5RC -B- 51.72 meters RADIO CARACAS CARACAS, VENEZUELA Sun. 8:30 a.m.-10:30 p.m., Daily 11 a.m.-1:30 p.m., 4-9:30 p.m.</p> <p>5790 kc. JVV -C- 51.81 meters NAZAKI, JAPAN</p> <p>5780 kc. OAX4D -B- 51.9 meters P.O. Box 853 LIMA, PERU Mon., Wed. & Sat. 9-11:30 p.m.</p>	<p>5720 kc. YV2RSC -B- 52.45 meters "LA VOZ de TACHIRA," SAN CRISTOBAL, VENEZUELA 6-11:30 p.m.</p> <p>5713 kc. TGS -B- 52.51 meters GUATEMALA CITY, GUAT. Wed., Thurs. and Sun. 6-9 p.m.</p> <p>5500 kc. T15HH -B- 54.55 meters SAN RAMON, COSTA RICA Irregularly 3:30-4, 8-11:30 p.m.</p> <p>5145 kc. PMY -B- 58.31 meters BANDONG, JAVA 5:30-11 a.m.</p> <p>5077 kc. WCN -C- 59.08 meters LAWRENCEVILLE, N. J. Phones England Irregularly</p> <p>5025 kc. ZFA -C- 59.7 meters HAMILTON, BERMUDA Calls U.S.A., nights</p> <p>5000 kc. TFL -C- 60 meters REYKJAVIK, ICELAND Calls London at night. Also broadcasts irregularly</p> <p>4975 kc. GBC -C- 60.30 meters RUGBY, ENGLAND Calls Ships, late at night</p> <p>4820 kc. GDW -C- 62.24 meters RUGBY, ENGLAND Calls N.Y.C., late at night</p> <p>4790 kc. VE9BK -B-X- 62.63 meters RADIO SALES SERVICE, LTD., 780 BEATTY ST., VANCOUVER, B.C., CAN. Daily exc. Sun. 11:30-11:45 a.m., 3-3:15, 8-8:15 p.m.</p> <p>4752 kc. WOO -C- 63.1 meters OCEAN GATE, N. J. Calls ships irregularly</p> <p>4600 kc. HC2ET -B- 65.22 meters Apartado 249 GUAYAQUIL, ECUADOR Wed., Sat., 9:15-11 p.m.</p> <p>4320 kc. GDB -C- 69.44 meters RUGBY, ENGLAND Tests, 8-11 p. m.</p> <p>4272 kc. WOO -C- 70.22 meters OCEAN GATE, N. J. Calls ships irregularly</p> <p>4250 kc. RV15 -B- 70.42 meters KHABAROVSK, SIBERIA, U. S. S. R. Daily, 1-10 a.m.</p> <p>4098 kc. WND -C- 73.21 meters HIALEAH, FLORIDA Calls Bahama Isles</p> <p>4002 kc. CT2AJ -B- 74.95 meters PONTA DELGADA, SAO MIGUEL, AZORES Wed. and Sat. 6-7 p. m.</p> <p>3040 kc. YDA -B- 98.68 meters N. I. R. O. M. TANDJONGPRAK, JAVA Daily exc. Sat. 6-7:30 p.m., 5:30-10:30 or 11 a.m., Sat. 8:30-11:30 a.m.</p>
---	---	---	--	--

W1XAL to Broadcast Astronomical Data

● GROUPS of scientists and research workers in all parts of the world will now be able to receive daily broadcasts of cosmic data, sunspots and magnetic disturbances via short wave from W1XAL in Boston Mass. President Walter S. Lemmon (W1XAL) inaugurated the new radio service starting February 1st. At 4:55 p.m. EST each weekday, bulletins known as URSIgrams are to be broadcast over W1XAL on 11.79 Mc (25.45 meters) and will be picked up by laboratories equipped with radio receiving sets not only in all parts of the North American continent but also in Europe, South Africa, and Australia as well. Weekly summaries of this data will be given each Monday evening at 8:30 p.m. on 6.04 Mc (49.67 meters).
Science Service at Washington is cooperating with W1XAL in this work. They have been com-

pling this scientific data daily for several years. Previously these bulletins have been mailed to selected lists of research workers and also transmitted in telegraph code from NAA, the Naval Radio Station in Arlington, Va., to a limited number of points. Now through the worldwide facilities of W1XAL this broadcast service will enable many thousands of scientific observers and amateur astronomers to receive up-to-the-minute information to assist them in their local observations. Through the cooperation of the Harvard Observatory reports of any unusual celestial phenomena will also be added to the broadcast as part of this scientific service.
The name URSIgram attached to these bulletins is derived from the initials of the Union Radio Scientifique Internationale (URSI) which formulated the original plan for gathering

cosmic data. The scientist who had much to do with the formulation of this idea is Professor A. E. Kennelly, of the Electrical Engineering Department of Harvard University, and co-discoverer of the Kennelly-Heavyside Layer which makes short-wave transmission possible.
Appearing with Professor Kennelly in this inaugural broadcast were Dr. Harlow Shapley, Director of the Harvard College Observatory, and Trustee of the World-Wide Broadcasting Foundation (W1XAL); and Dr. Loring B. Andrews, prominent Harvard astronomer and Chairman of the W1XAL Program Committee. Mr. Watson Davis of Science Service had his address broadcast by electrical transcription as he could not be present personally.

LET'S "Listen In"

With *Joe Miller*

● AS this article comes out, we can look forward to the DX cycle again swinging 'round, as, in mid-March, approximately, the 20 meter band begins to "open up," and Australians, Europeans, and a little sprinkling of Asiatics begin to push through on 20.

For the rest of the band, in general, we can expect signals to be heard with more volume, although with a bit more "background" noise than in the quiet winter season now waning.

New worlds are opened to the ardent DXer, to be conquered as conditions



SM5SX—The world-renowned S-W station at Stockholm, Sweden, heard by many American listeners.

for real DX improve. Spring reception really does help one get the hard ones, as we heard ZTJ in April, '35, with such a signal we did not believe we had heard this rare catch till we had received a veri, signed by Station Director, and congratulating us "upon our achievement." We would advise that all you seekers of the near impossible try for the African SW-BC stations, ZTJ, CR7AA, and VQ7LO, etc., as one can never tell when they may push through to the U.S., and conditions will be quite favorable, especially in late March, and April.

A certificate for VAC is being worked out and we hope to give full details as to how to obtain it in our May article. The certificate will be very handsome, and almost every DXer will be eligible for it. Watch for details, it'll be well worth your while!

Now to DX:

Welcome Martinique!

Radio Fort de France, on 9.44mc., and located at Fort de France, Martinique, in the West Indies, is being heard with a fine signal nearly daily from 8-9 p.m.

French announcements are made; program is made up of all sorts of music, from rhumbas to jazz, and English is spoken at the "sign-off."

This "catch" will add a new country to all DXer's logs, so we urge all to "log" them at once, and write for a veri

Our Short-Wave "DX" Editor

Winner of 30th "S-W. Scout" Trophy

Joe tells you about the new "VAC" certificate, also "how" and "when" to listen in and "catch" DX stations in China, India, Africa, Japan and Asia!

to be prized! A sure identification of this catch, which is heard just to the HF side of COCH, is the heavy hum apparent on station's carrier wave. The only QRA we have is mentioned in first two lines of this DX tip. Thanks to friend John De Myer for this FB tip!

XGOX Well Heard

The Nanking, China, station on 6.85 mc. came through consistently during January, although the terrific CW QRM near XGOX made reception on our SW58 regenerative set hopeless, so we had to resort to one of our "supers" to pull it through OK. A picture of XGOX's studio appeared in a previous issue.

Program "fare" consisted mainly of



"ZUIT" has a handsome and effective layout, you'll agree.

the native Chinese music, rather monotonous and gentle, played for as much as 20 minutes without a pause. Reports on XGOX should be addressed to Mr. P. F. Woo, Radio XGOX, Central Broadcasting Administration, Nanking, China.

Poona, India

VWY, Poona, the Indian commercial used by British Gov't for communica-

Australians on 20-meter phone will begin to come through around the first week in March. The best time to tune for "VK" Hams is from 12:30 to 3:30 a.m., with the peak period at 2 a.m., also try from 6 to 7:30 a.m.

This marks the beginning of conditions that will hold through the balance of the summer.

tion with the home Isles, was heard once just after 3 a.m., phoning Rugby.

However, although the station is listed near 8.98 mc. by several publications, a letter we have direct from the station states that VWY operates on 9037.5 kc., and that is where we heard this nice DX catch, just to the HF side of TYA2, the French commercial, often heard phoning and broadcasting in early a.m.'s on 9.04 mc.

Mr. N. Stahevitch, Hollywood, Cal., supports our reception on 9.037 mc., having heard VWY several times during the month. VWY contacts and phones GCI, Rugby, on 8.73 mc., often between 1:30 and 3:30 a.m.

Chinese Commercials

XOJ, Shanghai, 15.80 mc., is being heard quite well, between 9:30-11:30 p.m., usually phoning JVF, 15.61 mc., and at times JVE, 15.66 mc., both at Tokyo. Usually, XOJ phones in inverted speech, but calls and makes contacts in clear speech. Watch for this one, it is really easy to get now!

XGW, 10.42 mc., Shanghai, is coming in almost daily, with good strength, near 6:30-7 a.m. Another pair lately heard are XPC, 9.285 mc., and XGU, listed at 9.28 mc., but heard a bit lower in freq. (about 9.25 mc.)

As there has been much confusion as to wavelengths and locations of the many new Chinese stations reported, we cannot guarantee accuracy on any new station's listings, but have written the Chinese Government for a complete listing, which we hope will clear up everything.

Eddie Schmeichel reports XTC, 9.285 mc., calling Hangkow at 7:30 a.m.; also XTV, 9.49 mc. heard R9, 9:30-11 a.m. FB DX, Ed!

Our old reliable, Ashley Walcott of San Francisco adds: Shanghai now phones daily, except Sundays, from 9 to 11 a.m., using freq. of 7.41 mc., with a call sounding like XGB. This station phones KKY on 7.56 mc., at Dixon, California. Also, Hangkow, 5.48 mc., phones Shanghai on either 5.74 or on 9.285 mc.

To obtain reports on all of these commercials, write to Mr. T. C. Loo, Chinese Government, Radio Administration, Sassoon House, Jinkee Road, Shanghai, China.

Canary Islands

EAJ43, 10.38 mc., at Tenerife, is
(Continued on page 775)



ZUIT—This gorgeous card from South Africa is in green, yellow and red.

SHORT WAVE QUESTION BOX

EDITED BY
G.W. SHUART, W2AMN

● Because the amount of work involved in the drawing of diagrams and the compilation of data, we are forced to charge 25c each for letters that are answered directly through the mail. This fee includes only hand-drawn schematic drawings. We cannot furnish "picture-layouts"

or "full-sized" working drawings. Letters not accompanied by 25c will be answered in turn on this page. The 25c remittance may be made in the form of stamps, coin or money order. Special problem involving considerable research will be quoted upon request. We cannot

offer opinions as to the relative merits of commercial instruments. Correspondents are requested to write or print their names and addresses clearly. Hundreds of letters remain unanswered because of incomplete or illegible addresses.

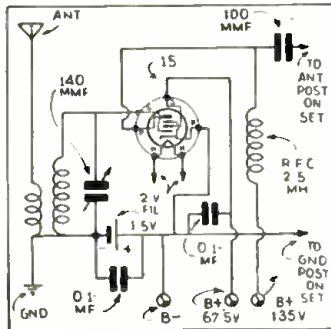

1-Tube Booster (1053)

SIMPLE BOOSTER

Roman Weza, Sobieski, Wisc.
(Q) Will you please print a diagram of a simple booster which appeared in the August 34 issue of *Short Wave Craft*, but for battery operation.

(A) We have shown the diagram you requested and have employed the type 15-tube. This should give excellent results when used in conjunction with a short-wave receiver. Standard 4-prong coils, data for which can be found in the February 1937 *Question Box*.

of a standard converter employing a 57 pentode as the detector and a 56 triode as an oscillator. The two output terminals of the converter should be connected to the antenna and ground posts of the receiver as indicated in the diagram. For best results the broadcast receiver should be tuned to a portion of the broadcast band which is comparatively clear of local interference, if such a thing is possible. In other words, do not tune on a strong station. It may be advisable to tune relatively close to one so that, should you desire the effect of a beat oscillator in this receiver, you can tune closer to one side of the station so that it heterodynes the same as a beat oscillator. Of course this method of heterodyning is only useful for code reception, where it is an easy matter to distinguish the voice of the weak broadcast station. We say weak broadcast station, because the antenna not being directly connected to the broadcast set, will reduce pick-up at the frequency to which the BC set is tuned.

2-STAGE BOOSTER

James R. Love, Harrisburg, Pa.
(Q) I have an *All-Star Senior* receiver which has given excellent results, however, I would like to add a 2-stage pre-selector employing 6K7 tubes. Kindly show the diagram in the *Question Box* giving all values

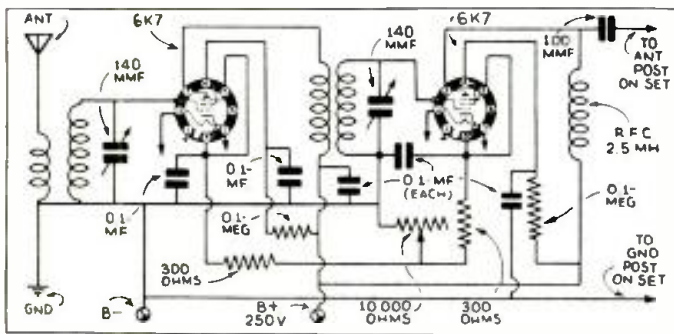

Two Stage Pre-Amplifier or Pre-Selector (1054)

S-W CONVERTER

Alex Brown, Tacoma, Wash.
(Q) I have an excellent broadcast receiver which does not cover the short-wave bands. Would you be kind enough to publish a diagram and explanation of a converter circuit which would give satisfactory results. This should not be too complicated.

(A) The diagram shown is one

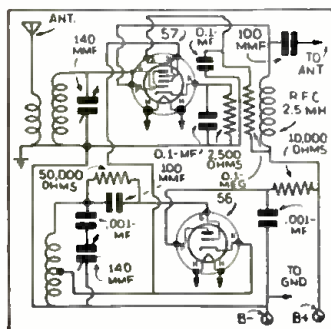

S-W Converter (1055)

and coil data together with information as to how it may be connected to my receiver. Also what advantage and improvements will I experience with this addition?

(A) We have shown the diagram as you requested. Standard 4-prong plug-in coils are employed, data of which has been given in the February *Question Box*. The two output terminals marked *antenna-ground* position connect to the antenna and ground positions of the receiver. The antenna and ground will then be connected to the front of the converter as shown in the diagram. These two stage boosters should increase the sensitivity of your receiver considerably, also it should eliminate or nearly so, the images which you are bound to experience where no pre-selection is employed. All in all, we believe it would be a worth-while improvement.

57, 56, 80 SHORT-WAVE RECEIVER

Abel Martinez, New Orleans, La.
(Q) I would be very much obliged if you would print a diagram in the next issue of the *Question Box* consisting of a 2-tube receiver employing a 57, 56 and type 80. I would

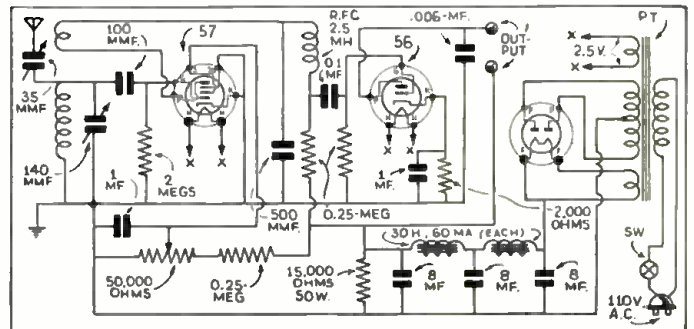

A.C. Operated 2-Tube (1056)

like to build an *all-electric* receiver and believe this would be the best to start with.

(A) The complete diagram is shown and you should have no trouble in getting it to operate perfectly at the first try, if diagrams and connections are followed. This power-supply shown may also be used with a 56-2A5 amplifier shown elsewhere on this page.

A. F. AMPLIFIER

F. G. Fong, Sacramento, Calif.
(Q) I would like to build an audio amplifier employing a 56-2A5 resistance-coupled combination. Will you please show the diagram and the necessary parts and their values in the *Question Box*. I would also appreciate a power-supply diagram for this amplifier.

(A) We have shown the diagram requested and have carefully indicated all the values and shown all the connections. If care is used in laying out this amplifier, it should give excellent results. However crowded or "bunched" connections may result in serious feedback or motorboating. Lay out the parts so that wiring is as direct as possible. Also grid and plate leads should be kept short! The power-supply diagram connections will be the same as that shown for the 57, 56 receiver, elsewhere on this page.

number of readers would be grateful for it.

(A) Most assuredly, any one can construct an antenna which is resonant at some particular frequency and one which will give excellent results. The one shown in the diagram is a single wire Hertz antenna the length, of course, is equal to 1/2 wavelength. To find its length in feet, multiply the desired wavelength in meters by 1.56. The feeder is tapped on to the antenna a short distance from the center of the antenna. This distance D, is equal to 14% of the total length of the antenna. As an example the 49 meter antenna would be 76.44 feet long, and the distance, D, would be 10.7

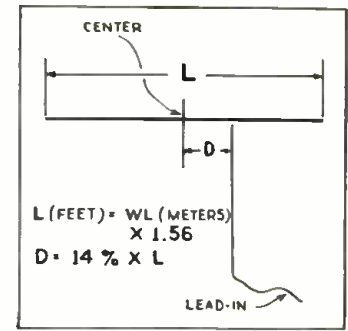

Receiving Antenna (1057)

RESONANT ANTENNA FOR S W I.

Arthur Squires, Paducah, Ky.
(Q) I would like to know if there is any way which I can design an antenna which would give satisfactory results on the 49-meter band, or in fact any short-wave band. If you can print such information in the *Question Box*, I believe a great

feet. The directional effect of the antenna is at right-angles to its plane and it is bi-directional. The lead-in should be brought away from the antenna at right-angles to it, for a distance equal to 30% of the length of the antenna. For those who concentrate their activities on a single band, this antenna should provide excellent results.

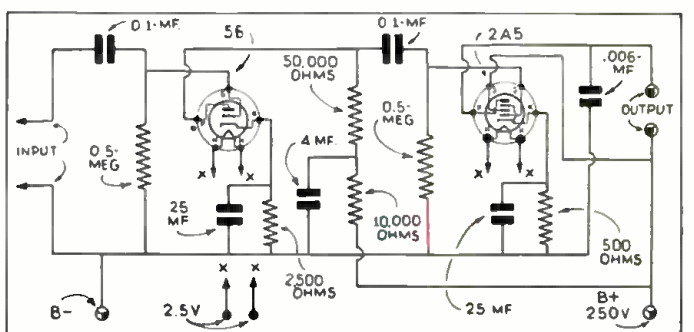

This A.F. Amplifier Has Many Uses (1058)

Names and addresses of manufacturers of apparatus furnished upon receipt of postcard request; mention No. of article.

Diagrams of S-W Commercial Receivers Hallicrafter Model S-15 "Sky-Challenger"

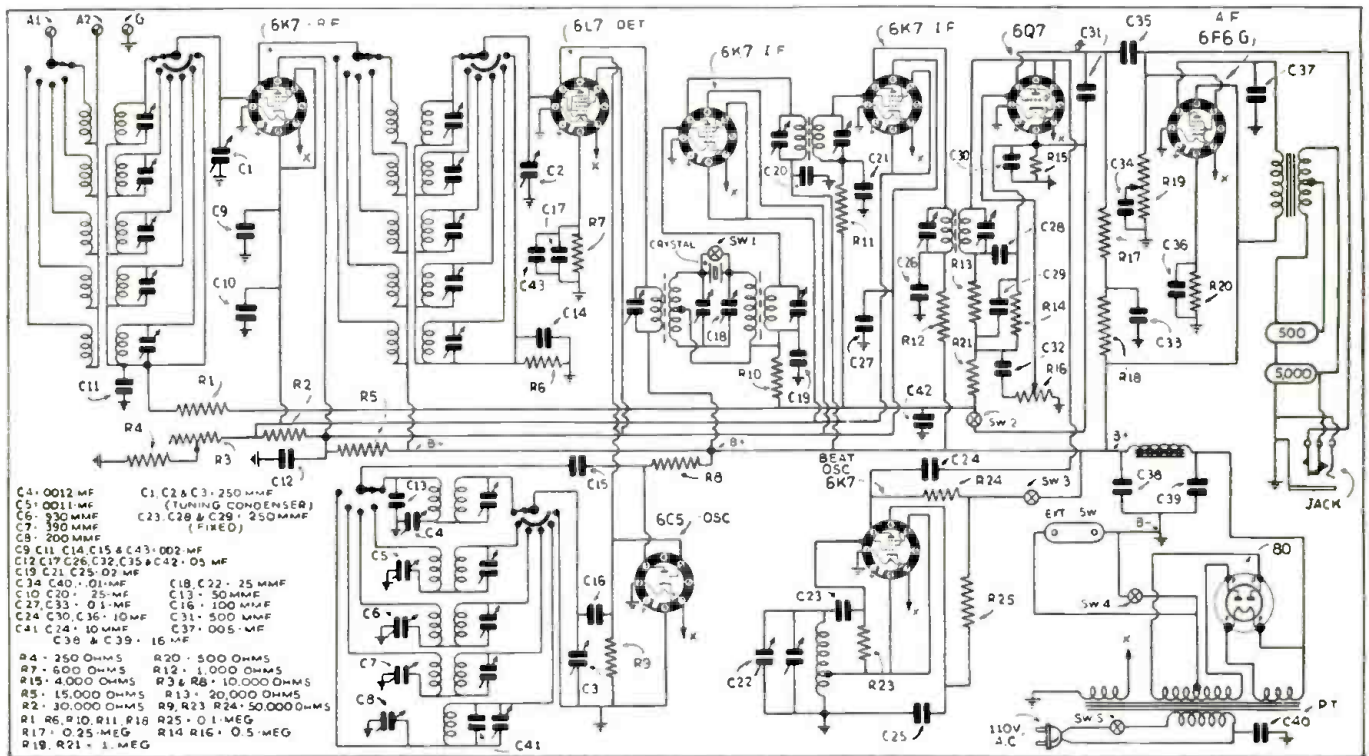

Above—This 9-tube all-wave receiver covers the short-wave and broadcast bands with a ganged band-switch. This set is available with or without the crystal filter; the filter is shown in our diagram. This crystal filter feature is especially desirable for Ham use. A phone-jack is provided, as well as tone and volume controls and a beat oscillator.

RCA Victor Model 7U2 Radio-Phonograph

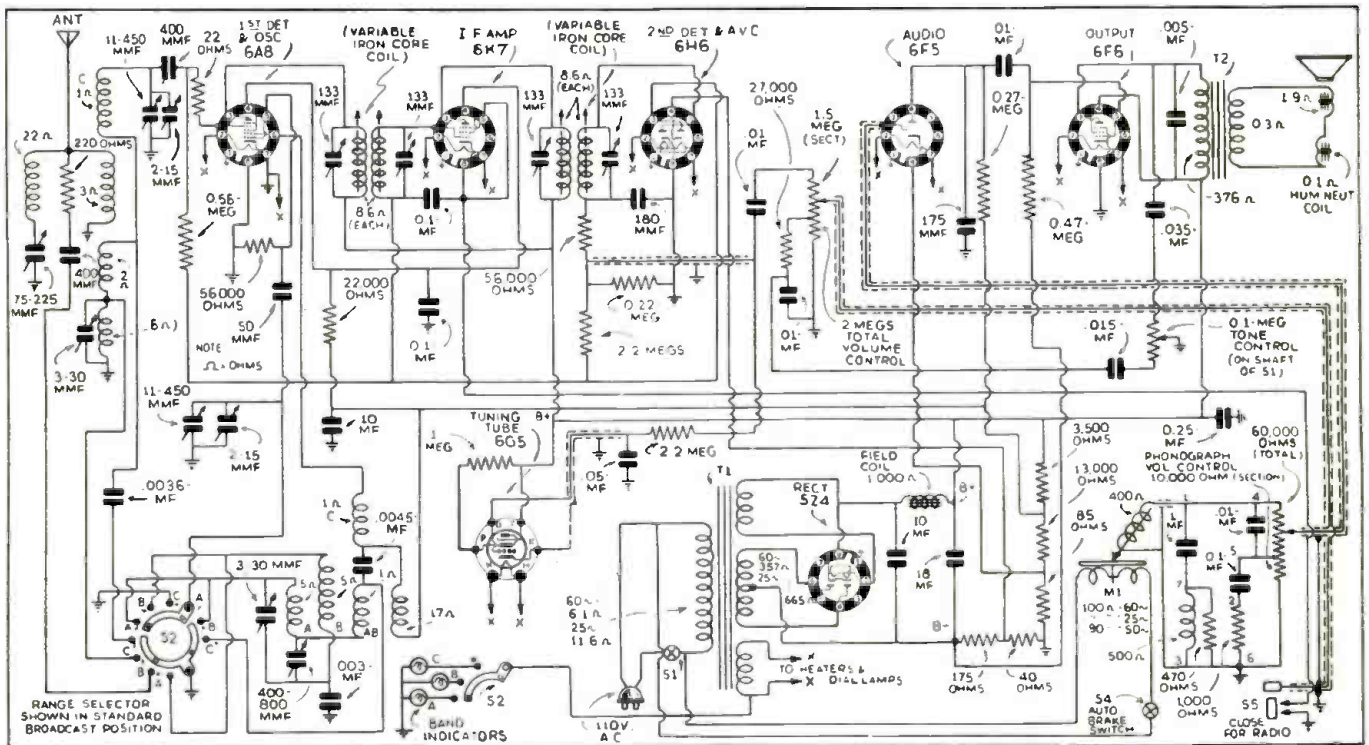

This radio-phonograph receiver covers three bands; 540-1625, 1625-5700, 5700-18,000 kc. The Int. Fre. is 460 kc. and 7 tubes are used. The radio set consumes 95-watts and with the phonograph in operation the set consumes 120-watts. A superhet circuit is used, with antenna wave-trap, magnetite core, adjusted I. F. transformers, A.V.C., Magic-Eye tuning tube, and full-wave rectifier. The phonograph motor is of the governor induction type and a switch permits of quickly changing the receiver from one band to another. Models for 105-125, 105-130, 140-160 and 200-250 volts, and 25, 50 or 60 cycle service.

NEW 1937 SHORT WAVE APPARATUS

(PROMPT SHIPMENTS ON ALL ITEMS)

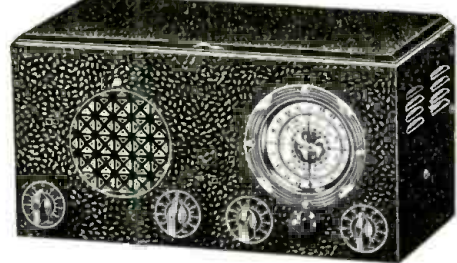

EILEN RX-17 7-tube BANDSPREAD RECEIVER

(8 1/2 to 3,000 meters)

Our largest, finest, and most sensitive new 1937 receiver, unequalled in appearance, performance and value. Uses a special, highly efficient and selective circuit producing results which WILL satisfy even the most discriminating short wave fan.

RX-17 is equipped with the famous EILEN NOISE SUPPRESSOR, the latest development of our laboratories and which is skyrocketing itself into immense popularity. This remarkable development, exclusive with EILEN, enables you to enjoy reception from those far-off stations with excellent clarity and volume.

Constructed of the finest materials and to conform with the highest engineering standards, this instrument uses two 6B6, two 6J5, one 7C, one 2Z, and one 5Y3 high gain tubes as TUNED RF AMPLIFIER, TUNED ELECTRON COUPLED SCREEN-GRID REGENERATIVE DETECTOR, powerful 3 stage audio frequency amplifier with power pentode output stage delivering 3 watts of audio power to the built-in high fidelity loudspeaker. VARIABLE NOISE SUPPRESSOR, rectifier and complete built-in HUM-FREE power supply. BANDSPREAD TUNING—a special electron tube circuit enabling the operator to reduce or eliminate certain types of noises occurring in all short wave receivers—automatic headphone jack—smooth and noiseless controls—highly efficient interchangeable inductors—doublet or aerial-ground connections—POWERFUL hi-fidelity audio system—large, illuminated airplane type vernier dial—sensitivity, volume, and selectivity that will amaze you—are features to be found in RX-17.

RX-17 in BEAUTY, as well as performance, is in a class by itself—heavy steel cabinet with hinged lid finished in durable black shrieve-colored dial lights behind black and white scale—chrome plated escutcheon—calibrated dial plates—plated chassis and shielding—Operates entirely from your 105 to 130 volts AC house current.

RX-17 under fair conditions will bring in dozens of foreign as well as domestic short wave stations with enormous volume. Try one and see for yourself!

RX-17, complete, READY TO USE, with 7 RCA or Sylvania tubes, 12 low-loss silver plated coils for 8 1/2 to 3000 meters, wired, in cabinet, and 7 page instruction booklet.....

\$21.95

For those who wish to build their own **\$14.95**

Kit of all parts, coils for 8 1/2-3000 meters, unwired (less tubes & cabinet).....
 7 matched Sylvania tubes, extra.....\$2.50
 Wired and tested, extra.....2.00

AMATEURS: Model RX-17-AB has same specifications as RX-17 except that it is equipped with plate voltage cut-off switch and special bandspread coils for 20-40-80-160 M bands spreading these bands 80% of dial scale. Add \$1 to price of RX-17, (10 meter band coils if desired extra \$1.45).

(If metal tubes are preferred over the glass type, add \$1 to above price.)

RX-18 8-TUBE BAND SPREAD RECEIVER

(2 1/2 to 3,000 meters)

RX-18 and RX-18-AB have the same specifications as the above RX-17 and RX-17-AB, but is equipped with an EIGHTH TUBE (6J5G) enabling the wavelength range to be extended down to 2 1/2 meters. This additional tube is designed especially for ultra-high frequency wavelengths. This receiver is exceedingly simple to operate with excellent results.

ADD \$4.50 to price of corresponding RX-17 or RX-17-AB model. Prompt delivery can be made.



BS-5

6-Tube Band switch Receiver

10 to 600 Meters

A powerful, sensitive, and selective SW receiver covering the entire wave-length span of 10 to 600 meters in 5 steps. NO TUNING COILS are used. Simply turn the waveband selector switch and enjoy reception on any wavelength within this range.

Uses two 6B6, one 7C, one 4Z, one 6J5A, and one 25Z5 tubes as RF amplifier, electron coupled screen grid regenerative detector, powerful 2 stage audio amplifier with pentode output stage, rectifier, and complete built-in power supply.

HUM-FREE—hi-fidelity dynamic loudspeaker—Illuminated, airplane type vernier dial—band spread tuning control—automatic headphone jack—extremely smooth acting controls—operates from your AC or DC house current—beautiful heavy, black shrieve finish chassis and cabinet.

DELIVERS CLEAR TUNING-SPREAD VOLUME ON THE GREAT MAJORITY OF SHORT WAVE FOREIGN STATIONS UNDER FAIR CONDITIONS.

PRICE, complete with 6 tubes, cabinet, wired, and instructions, ready to use.....



See editorial article Page 482, Dec. issue S.W.C.

\$16.95

BS-5 KIT, of necessary parts, including detailed instructions; less tubes, cabinet, unwired.....

\$10.95

SPECIAL: Complete kit, cabinet, tubes and instructions, unwired.....

\$14.95

(If metal tubes are preferred to glass type, add \$1)

AMATEURS: Model BS-5-AB has same specifications as BS-5 except that it has special bandspread circuit for 20-40-80-160 M bands and is equipped with plate voltage cut-off switch. Add \$1.00 to above price.

7C 5-Tube Short Wave Receiver

8 1/2 to 625 meters

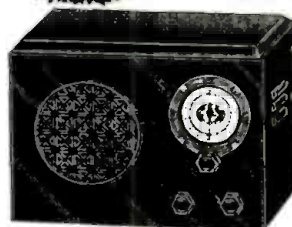

Bigger and More Powerful Than Ever A Giant in Performance

FULL 6 TUBE PERFORMANCE plus THE NEW K02A SERIES TUNING makes this an outstanding value. Equipped with a powerful 3 stage audio frequency amplifier.

Uses 6D6-6F7 (twin 2 in 1 tube)—7C—K02A.12A7 (twin tube) tubes as RF amplifier, electron coupled screen grid regenerative detector, powerful 3 stage audio amplifier with pentode output stage, rectifier and complete built-in power supply. Operates entirely from 105 to 130 volt AC or DC light socket.

BAND SPREAD TUNING—smooth regeneration control—built-in high quality loudspeaker—automatic headphone jack—large illuminated airplane type vernier dial—large low-loss inductances. Heavy, black shrieve finish metal chassis and cabinet. Must be seen to be appreciated. Satisfied owners report as high as 35 foreign countries on the loudspeaker with this model. YOU may do the same under fair conditions. ORDER YOURS TODAY! YOU WILL NOT REGRET IT!

EILEN 7C RECEIVER, wired, in cabinet, complete, READY TO USE, with speaker 5 RCA tubes, 4 coils for 8 1/2 to 200 meters, and simple instructions.....

\$12.95

2 broadcast band coils, extra.....\$1.25

7C KIT, unwired, of necessary parts, coils for 8 1/2 to 200 meters, and instructions less cabinet, speaker, tubes.....

\$7.25

Beautiful metal cabinet, extra.....\$1.25

5 matched RCA tubes.....\$3.15

Special loudspeaker.....1.45

(2) Broadcast band coils, 200-625 meters.....1.25

labor for wiring & testing, extra.....1.50

SPECIAL: COMPLETE KIT, unwired, cabinet, 5 tubes, speaker, 4 coils for 8 1/2 to 200 meters, and simple instructions.....

\$11.45

2 broadcast coils, extra.....\$1.25

AMATEURS: Model 7C-AB, same specifications as 7C except that has special tuning circuit and coils for spreading out the 20-40-80-160 M bands over 80% of dial. Also equipped with plate voltage cut-off switch. Same price as 7C. Model 6B or 6B-AB battery model of 7C. Operates from inexpensive dry batteries. Same price.

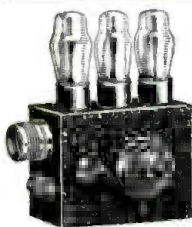

3-Tube Short Wave Radio

Only \$3.25

(less tubes, phones, unwired)

A REAL, powerful 3 tube short wave set that readily brings in amateurs, police calls, broadcast stations, experimental and foreign stations with good volume under fair conditions. THE WORLD AT YOUR DOOR!

THREE TUBE BATTERY SET, less tubes, phones, unwired \$2.95

TWO TUBE BATTERY SET, less tubes, phones, unwired \$2.00

KITS wired, extra 75c. Tubes, each 50c. Broadcast band coils (2), extra 10c. Cannonball double headphones \$1.35.



HF-35 3-Tube SW Transmitter

A powerful and well engineered amateur band transmitter of great beauty and efficiency—AT A PRICE WITHIN THE AMATEUR'S REACH. Uses 50-41-40 tubes as TRITET CRYSTAL CONTROLLED OSCILLATOR—CLASS C RF POWER AMPLIFIER—built-in antenna tuning system—beautiful, black shrieve metal case and shelve-inc.—Triplett meters—Eilen transmitting dials—highest quality construction—35 watts of power output on 20-40-80-160 M bands. A transmitter that you can be proud to own. An excellent exciter unit for high power stages to be added later. 3 coils for any 3 bands and instructions included.

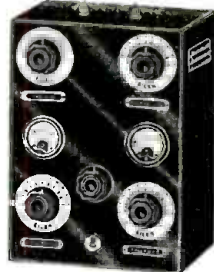

HF-35, assembled, and ready to wire (less tubes, power supply, crystal, holder and additional coils).....

\$21.95

Matched Arcatrus tubes (3).....\$2.15

Eilen quartz crystal (80 or 160).....\$1.95

Eilen crystal holder.....1.00

Coils for additional bands, per set.....1.45

HV-475 1-Tube power supply for use with HF-35, less tube.....\$12.45

ready to wire.....Labor for wiring extra

83 tube for HV-475, extra 55 cents

M-15 3-Tube Modulator for use with HF-35 and capable of modulating its entire output at 100% priced at \$14.95 (less tubes)

Three Arcatrus tubes, 66-53-53, extra.....\$1.95



AN-5 Four Tube BANDSPREAD RECEIVER

A powerful and highly selective short wave receiver, tested and tested for the fan who prefers the use of headphones.

Uses 6F7-6D6-7E-84 tubes in five-tube performance. Circuit as TUNED RF amplifier, screen grid regenerative detector, two stage audio amplifier, rectifier & built-in power supply. HUM-FREE. POWERFUL. Beautifully operates a speaker. Operates from your 105-130 volt AC house current.

AN-5, complete with 4 matched tubes, coils for 9 to 200 meters, cabinet, wired

READY FOR USE.....

\$15.95

Broadcast band coils (2), extra.....\$1.45

TUNED electron coupled screen grid regenerative detector, two stage audio amplifier, rectifier & built-in power supply. HUM-FREE. POWERFUL. Beautifully operates a speaker. Operates from your 105-130 volt AC house current.

AMATEURS: Model AN-5-AB has same specifications as AN-5 except that has plate voltage cut-off switch and special bandspread coils for 20-40-80-160 meter bands. Add \$1 to price of AN-5.

FREE: New 1937 catalogue

of short wave receivers, transmitters, & 5 meter apparatus. Send stamp to cover mailing costs on YOUR copy.

JUST OFF THE PRESS!

Prompt service, 20% deposit on C. O. D. orders

EILEN RADIO LABORATORIES, Dept. SC 4, 136 Liberty Street, NEW YORK, N. Y.

*Reprint from Ace Radio Catalog
Send in Your Order to address below-*

the UNIVERSAL-SIX
8 1/4 to 625 Meters—Four Tubes
AC—DC—BATTERY

IMAGINE!! A compact, self-contained sensitive receiver with real SIX TUBE performance that will operate on any AC or DC house line or on batteries, without making any changes. The Ace Universal-SIX will operate anywhere! Simply plug in a cable and—**PRESTO!** A completely battery operated set with the same full toned loud speaker volume—the same miraculous ease of operation! Really same thrilling foreign reception—the same TWO good receivers for less than you would expect to pay for either one! **POWERFUL** tube line-up: 6F7 screen grid pentode I.F. stage and first audio stage—6B7 Electron coupled regenerative detector and second audio stage—38 third audio pentode output stage—1-V heater type rectifier for humless power supply! Every tube serves a useful audio purpose—no "ballast" tubes to make the set appear larger!



ACE UNIVERSAL-SIX receiver with four tubes, cabinet, all coils, and built-in speaker. **COMPLETE!** Nothing else to buy. Not wired. Laboratory wired and tested, complete, ready to plug in. **\$12.65**
\$14.15
\$5.50

NOTE: If tubes, speaker, Broadcast Band coils, and cabinet are not desired at present you may deduct from the above prices

More features: Full Bandspread 8 1/4 to 625 meters—self-contained speaker—transmitter type dual speed full vision dial—provision for headphones—velvet smooth control of regeneration—operates entirely on AC, DC, or Batteries—Low current drain with high output means real economical operation
ORDER YOUR "UNIVERSAL-SIX" NOW!
Every one fully guaranteed! Buy with safety!

the Do-all DeLuxe



FEATURING TWO MODELS TUNING FROM 2 1/2 TO 3000 METERS
continuous range 100 Kc. to 120 Mc.—no skips!
DUPLEX REGENERATION CONTROL: Semi-automatic regeneration keeps detector at peak!
FULL BANDSPREAD: Two new transmitter type dials with built-in dual speed drive!
TUNED RADIO FREQUENCY AND TUNED DETECTOR STAGES— A positive essential for sharp tuning!
6K7-6K7-76-76-76-42-5Y4G
See December S.W.C. page 491 for more detailed description.

(Supplied without rack mounting ends (illustrated). This may be added later.)

DO-ALL DELUXE
STANDARD MODEL (9 to 3000 Meters)
Six tube Receiver, complete with matched tubes, and cabinet. Nothing else to buy! (Not wired) Laboratory wired and tested. Ready for you to attach antenna, plug into socket and thrill to new and strange programmes!
Price **\$21.75**
If tubes, cabinet, and 200 to 3000 meter wavelength range are not desired at present you may deduct from the above prices **\$5.00**

DO-ALL DELUXE
ULTRA MODEL (2 1/2 to 3000 Meters)
Seven tube Receiver, complete with matched tubes and cabinet. Ready to be wired. Laboratory wired and tested. Ready to operate. The entire world of Radio at your command! Complete **\$26.25**
If tubes, cabinet and 200 to 3000 meter wavelength range are not desired at present you may deduct from the above prices **\$5.00**

Model—"R-9" THREE TUBE TRANSMITTER
GET ON THE AIR NOW WITH THIS FB RIG!!

Here's a well engineered xmitter that parks a healthy "wallop" 1'p to 16 Watts of clean crisp power that places your sicks into all parts of the globe. Uses the sensational new 6L6 beam controlled or tube as a power amplifier driven by a 76 crystal controlled or TNT oscillator. Works with or without a crystal on all bands. Heavy built-in power supply using 43-V rectifier gives ample current. Plugs into any 110 volt AC house line. Accurate milliammeter reads all circuits with special switch. Simple to tune and operate. Clear instructions.



ACE R-9 TRANSMITTER
Complete kit of all parts with sturdy metal chassis and panel with all holes drilled, ready to assemble and wire (less tubes, mounted on crystal coils). Wired and tested. Set of matched tubes \$2.15. Mounted crystal \$2.45. Set of coils for any Amateur Band—\$1.00.
\$12.75

ACE R-9 SPEECH AMPLIFIER-MODULATOR
(Using 76—6C6—6L6—43-V Tubes)
Attach two wires from this unit to terminals on your R-9 Transmitter and you have a full power, high quality phone station with 100% modulation. Has its own built-in heavy-duty power supply. High gain speech amplifier insures high fidelity response. Smooth gain control. (This unit, plus a speaker, makes an excellent Resistor-coupled amplifier for public address, etc.) Complete ACE R-9 SPEECH AMPLIFIER-MODULATOR. Not wired. One tube, microphone. Set of four guaranteed tubes—\$2.95. Wired and tested—\$2.50 extra.
\$9.75

VALUE!

SERVICE!

One Meter Waves for "Short Haul" QSO's

(Continued from page 737)

This resistance can be a short length of resistance wire, the proper length determined with the use of a voltmeter, the exact resistance should be .1369 ohms.

The modulator used with the transmitter, but not shown in the photographs, consisted of a pair of 2A5's in class A.B. However, any audio unit with about 15-watts output will be entirely sufficient.

In the test conducted all known rules on ultra-high frequency transmission were found to be predominant. In other words, the higher the antenna, whether it is for receiving or transmitting, the better the signal strength; also hills have an appreciable effect on the signal, when either the transmitter or receiver are located close to the base of the hill. The ill-effects of the hills becoming less noticeable as the transmitter or receiver is moved farther away from it.

All in all, our tests proved that the amateur can occupy the ultra high frequency region with just as much satisfaction as he now can obtain from the 5-meter band. The Author wishes to thank Al Kuhnert (W2BGY) for his assistance in carrying out the above mentioned tests.

One Meter Set—Parts List

- OSCILLATOR**
1—WE-316A tube
- CORNELL DUBELIER**
2—.001 mf. 1,000 volt condensers
- ELECTRAD**
1—10,000 10-watt resistor
1—100 ohm center tapped resistor
- POWER SUPPLY**
1—power transformer; see diagram for ratings
1—12 H. 130 ma. filter choke
- SPRAGUE**
2—4 mf. 500 V. electrolytic condensers
- ELECTRAD**
1—25,000 ohm 50 watt resistor
- RCA RADIOTRON**
1—type 80 tube
- RECEIVER RESISTORS—IRC**
1—1/4 meg. resistor 1/2-watt
1—50,00 ohm resistor 1/2-watt
1—500 ohm resistor 1-watt
1—50,000 ohm resistor 1-watt
- ELECTRAD**
1—50,000 ohm potentiometer
1—1/2-meg. potentiometer
- CORNELL-DUBILIER**
3—.0001 mf. mica condensers
1—.001 mica condenser
2—.1 mf. paper condensers
1—.01 mf. paper condenser
1—25 mf. electrolytic condenser
- CARDWELL**
1—Trim-Air 2-plate condenser with split stator (ZV-5-TS)
- HAMMARLUND**
1—Acorn tube socket
- MISCELLANEOUS**
1—6-prong wafer socket
- RCA RADIOTRON**
1—955 Acorn tube
1—41 tube

Amateur Radio and the Flood

(Continued from page 727)

handled expeditiously.
IT IS ORDERED that no transmissions except those relating to relief work or other emergencies be made within any of the authorized amateur bands below 4000 kilocycles until the Commission determines that the present emergency no longer exists.
By the Commission:

JOHN B. REYNOLDS,
Acting Secretary.

The Commission authorized the American Radio Relay League to appoint amateur "vigilantes" to disseminate the order and secure its observance.

CLIP THIS COUPON

Please send me your free catalog fully describing Ace Products.

Name

Address

C-4 Catalog No. 24

ACE RADIO LABORATORIES
70 BARCLAY ST., Dept. C-4, NEW YORK CITY
THE HOUSE OF VALUE AND SERVICE

Please mention SHORT WAVE & TELEVISION when writing advertisers

THE NEW DOERLE

•Continuous bandspread tuning from 9 1/2 to 625 meters.
 •Beautiful, large illuminated dual pointer, multi-colored, airplane type dial of great beauty.
 •Operates from either single wire type aerial or noise-free doublet.
 •Volume control—stage aligning trimmer—and tone controls.

•Uses (6K77, 6K7G, 6C5G, 6F5G and 5Y3) tubes in a highly efficient circuit, using two tuned stages—electron coupled regenerative detector—POWERFUL 3 stage resistance capacity coupled audio amplifier with power pentode output stage—high voltage rectifier and self contained hum-free power supply. Built-in High Fidelity dynamic speaker capable of handling the entire 3 watts power output of the receiver.
 Continuous bandspread over 9 1/2 to 625 meters is obtainable due to the use of a special type, multi-colored, airplane dial having 125 to 1 ratio and two pointers. Two knobs are provided and make possible either fast or slow motion tuning. ALL of the AMATEUR and FOREIGN SW BANDS are spread over a generous portion of the turn of the dial, thereby simplifying tuning so that even a beginner can operate it to the utmost satisfaction. Entirely free from all traces of backlash.

The entire unit is contained in a large, black crackle finished metal chassis and cabinet of extreme beauty. Simply plug into your electric light socket and enjoy an evening of short wave thrills and entertainment such as you have never before experienced.
 Mechanical specifications: Dimensions are 17 1/2"x11"x8 3/4". Net weight 23 lbs. Shipping weight 33 lbs. Designed to operate entirely from 100-110 Volts, 50 to 60 cycles AC house current. Shipment made same day as order is received. Complete satisfaction guaranteed.
 DOERLE 6 tube AC BANDSPREAD RECEIVER, completely wired and tested, with set of 6 matched Arcturus tubes, 3 coils for 9 1/2 to 200 meters, cabinet, instructions, and READY TO OPERATE.
 (Specify whether metal or glass tubes desired.)

6 Arcturus matched tubes.....\$3.12
 Broadcast band coils (2).....1.45

6 - Tube BANDSPREAD RECEIVER MARVELOUS Sensitivity and Selectivity Only Found in the Higher Priced Models

•Unusually smooth acting regeneration control.
 •Headphone jack with plate voltage cut-off switch.
 •Highly efficient, low loss ribbed plug-in coils, are a large factor in the amazing sensitivity and selectivity of this receiver. Coils are of the large 3 winding variety and are color coded for easy identification.

•Uses (6K77, 6K7G, 6C5G, 6F5G and 5Y3) tubes in a highly efficient circuit, using two tuned stages—electron coupled regenerative detector—POWERFUL 3 stage resistance capacity coupled audio amplifier with power pentode output stage—high voltage rectifier and self contained hum-free power supply. Built-in High Fidelity dynamic speaker capable of handling the entire 3 watts power output of the receiver.
 Continuous bandspread over 9 1/2 to 625 meters is obtainable due to the use of a special type, multi-colored, airplane dial having 125 to 1 ratio and two pointers. Two knobs are provided and make possible either fast or slow motion tuning. ALL of the AMATEUR and FOREIGN SW BANDS are spread over a generous portion of the turn of the dial, thereby simplifying tuning so that even a beginner can operate it to the utmost satisfaction. Entirely free from all traces of backlash.

The entire unit is contained in a large, black crackle finished metal chassis and cabinet of extreme beauty. Simply plug into your electric light socket and enjoy an evening of short wave thrills and entertainment such as you have never before experienced.
 Mechanical specifications: Dimensions are 17 1/2"x11"x8 3/4". Net weight 23 lbs. Shipping weight 33 lbs. Designed to operate entirely from 100-110 Volts, 50 to 60 cycles AC house current. Shipment made same day as order is received. Complete satisfaction guaranteed.
 DOERLE 6 tube AC BANDSPREAD RECEIVER, completely wired and tested, with set of 6 matched Arcturus tubes, 3 coils for 9 1/2 to 200 meters, cabinet, instructions, and READY TO OPERATE.
 (Specify whether metal or glass tubes desired.)

YOUR NET COST
\$27.96

less 2 Broadcast band coils, extending the range up to 625 meters, extra \$1.45.



DOERLE 6-tube AC SW KIT, containing all necessary parts, including 8 low loss ribbed coils for 9 1/2 to 200 meters, full size, highly dynamic speaker, beautiful cabinet, and 4 page instruction booklet (less tubes).....**\$17.96**

DOERLE 2-TUBE BATTERY RECEIVER



One of the most popular members of the Doerle Set family. Employs but two tubes, yet will outperform many three and four tube receivers. Uses two type 30 tubes as regenerative detector and one stage of transformer coupled audio frequency amplification. Delivers enormous headphone volume on all signals. Easily operates a loudspeaker on many stations.
 The world-famous reputation of the entire Doerle line is behind this remarkable set. Requires two dry cells and one or more 45 volt "D" batteries for operation.
 Extremely simple to build and operate. Complete and detailed diagrams and instructions included.

DOERLE 2-TUBE BATTERY RECEIVER KIT (un-wired), less tubes cabinet, B.C. coils and batteries, including coils for 10 to 200 meters, and instruction booklet.....**\$4.95**
 Set of two MATCHED RCA tubes.....\$0.80 extra
 Metal cabinet, black shrivel finished 1.25
 2 broadcast band coils, 200-550 meters.....1.25
 WIRED & TESTED, extra.....1.50

THREE TUBE BATTERY OPERATED DOERLE SHORT WAVE SET

9 TO 200 METERS

This powerful Doerle receiver has been especially designed for the short wave fan or amateur who wishes an unusually selective and sensitive battery operated model.
 Uses one 34, one 19 and one 33 tubes as TUNED RF AMPLIFIER, (TUNED) SCREEN GRID regenerative detector, powerful 2 stage audio frequency amplifier with pentode output stage. Extremely selective—will separate very easily the great majority of stations in the crowded foreign bands.

1. Tremendous headphone volume—readily operates a loudspeaker if desired.
2. Connection block on rear chassis allowing the use of either a doublet or a single wire type antenna.
3. Large, illuminated, airplane type of vernier dial of great beauty.
4. Well shielded—preventing all traces of feedback between stages.
5. Large, ribbed, low-loss, silver plated coils of high efficiency, color coded for easy identification.
6. Smooth regeneration control, free from all noise and traces of fringe howl.
7. Band spread station selector control, simplifying tuning so that even a beginner can obtain excellent results from this receiver.
8. Simple and economical to operate. Requires one A battery, one C battery, and 45 to 90 volts of B battery.
10. Beautiful, heavy black crackle finished metal chassis, panel, and cabinet with hinged cover.
11. Dimensions are 11" x 7 1/2" x 7 1/2". Shipping weight 17 lbs.

PRICE, complete, ready to use with 3 tubes, cabinet, coils for 200 meters; wired, less B.C. cabinet, coils for 200 meters, with 4 page instruction booklet (less batteries).....**\$12.95**
 (2 broadcast band coils, extra \$1.45) (Burgess batteries, per set, extra \$3.30)

THREE TUBE DOERLE BATTERY KIT, including drilled chassis and panel, all parts, coils for 200 meters, and instruction booklet, less cabinet, tubes, B.C. coils, phones, unwired.....**\$7.95**
 Crackle finished steel cabinet, extra.....\$1.25
 Set of 3 MATCHED RCA tubes, extra.....1.85
 Wired and tested, extra.....1.50
 Broadcast band coils (2), extra, per set.....1.45
 Cannonball double headphones, 2000 ohm, extra.....1.35

THREE TUBE DOERLE AC SHORT WAVE SET

9 TO 200 METERS

These three tube receivers are low in price—yet, inexpensive as they are, they pull in short wave stations from all over the world with excellent volume and regularity. Designed so as to conform to the highest engineering standards and constructed of the finest material, these receivers are W I I. I. please you.
 Tubes used are one 6F7 (twin dual purpose tube), one 41 and one 84 functioning as screen grid regenerative detector, powerful two stage audio frequency amplifier with power pentode output stage, rectifier and built in power pack. Hum free in operation. Four tube performance. Produces enormous headphone volume and will readily operate a loudspeaker at full capacity on practically all stations.
 Contains all of the latest features that can possibly contribute towards making this an outstanding value.

1. Illuminated airplane type vernier dial of extreme beauty.
 2. Electron coupled screen grid regeneration circuit.
 3. Unusually smooth regeneration control.
 4. Band spread vernier control condenser.
 5. Large low-loss silver plated inductances (band spread coils if desired).
 6. Low loss equipment and construction throughout.
 7. Cadmium plated chassis of high electrical conductivity.
 8. Beautiful, black crackle finished steel panel and cabinet with hinged lid.
 9. Operates from your AC house current.
- PRICE, complete, ready to use, wired with 3 tubes, cabinet, coils for 9 to 200 meters, less B.C. coils and phones, with 4 page instruction booklet.....**\$11.95**
 (2 broadcast band coils, extra \$1.45)

THREE TUBE DOERLE AC KIT, including drilled chassis and panel, all parts, coils for 9 to 200 meters, instructions and instruction booklet, unwired, less cabinet, tubes, B.C. coils and phones.....**\$6.95**
 Crackle finished steel cabinet, extra.....\$1.25
 Set of 3 MATCHED RCA tubes, extra.....2.15
 Wired and tested, extra.....1.75
 Broadcast band coils (2), extra.....1.45
 Cannonball headphones, 2000 ohm, extra.....1.35

GUY STOKELY RADIO CORPORATION, 126 Liberty St., Dept. S-4, New York City
 Sole manufacturers and distributors of Doerle products
 20% deposit on C.O.D. orders. Prompt shipment
FREE: Catalogue of Doerle Receivers sent upon request

Television and the Electron

By Dr. Vladimir K. Zworykin
 (Continued from page 725)

of the Kinescope and, consequently, is dependent on the physical size of the tube. Laboratory experiments indicate that there is every reason to believe that it will be possible to build tubes giving a small picture of sufficient brilliancy to be projected upon a large viewing screen. Experimental models of this type of projection tube have been made which very nearly meet the requirements of television. Continued improvements in the electron gun and in fluorescent material will unquestionably make this type of Kinescope entirely practical.
 These are only two of the many examples that might be given of the progress that may be expected. Next year and the year after, examples which do not exist today can be given. In other words, the electron system has not yet even emerged from early childhood. Only the most incorrigible pessimist, the man who has an honest doubt about the sun's rising tomorrow, believes the cathode ray television is a closed field, that all is known about it that can be known.
 Assuming that the system as it stands

NEW HAMMARLUND BULLETIN

• A brand new catalog, No. 37, has just been issued by the Hammarlund Manufacturing Company, its beautiful artistic appearance is due to the guiding hand of Lewis Winner. All of the variable condensers illustrated are presented with complete specifications, including accurate "black-board" diagrams of their dimensions, as well as calibration curves showing the capacity in mmf. for different numbers of dial divisions.
 Every radio set-builder should have a copy of this informative bulletin on his study table, as complete data is given on various types of plug-in coil forms, sockets, R.F. chokes, and the very latest type of variable coupling I.F. transformers. A technical description of the new Super-Pro receiver is included. Ask for a copy of bulletin No. 902.
 Service Dept.
SHORT WAVE & TELEVISION,
 99 Hudson St., New York City, N.Y.

today can produce a fairly satisfactory picture and that there is every reason to look for marked improvements in the near future, let us ask what will be required of television if it is to become popular in the sense that radio broadcast is popular.
 Considering first the receiver, the entertainment supplied by the receiver must be such that it can be made incidental to the normal household activities. In other words, television is not and should not be intended to take the place of the observer's going in person to see an event in which he is intensely interested. The sport fan will still go to the baseball field, the football game or the boxing arena, the theatre lover will still go in person to see the plays in which he is interested, television or no television. However, to the individual who is not sufficiently interested in an event to expend the time and effort to become an eye witness, television will bring a summary of what is taking place. This means that the receiver must be small enough so that it will not be objectionable as a piece of furniture. It must be simple in operation and arranged so that it does

Please mention SHORT WAVE & TELEVISION when writing advertisers

SHORT-WAVE IMPROVEMENTS

By Clifford E. Denton

NOISE-SILENCER

BEAT OSCILLATOR

Meissner offers these two Short-Wave improvements - Completely assembled and ready to wire. All parts furnished with detailed step-by-step instructions. **LIST PRICE \$11.50**

SOLD BY ALL LEADING JOBBERS

MEISSNER MFG. CO. MT. CARMEL, ILL

not require setting up of viewing screens or any other elaborate preparation. The picture should be bright enough so that it can be readily seen in a moderately lighted room, and small enough not to be too obtrusive, perhaps one-and-a-half by two feet in size. In a sense, the receiver might be considered as a window through which the individual may, in the course of conversation or reading, glance to see what is going on in the world around him.

The television pickup device, to be completely satisfactory, must be sufficiently sensitive not only to reproduce scenes of average illumination but should also be operative at very low light levels. Imagine the feelings of the spectators looking at a football game if the last few minutes' play cannot be transmitted due to insufficient light. The Iconoscope of today, while it will suffice for ordinary weather conditions, would not be operative in the semi-darkness of late afternoon in November. However, as was pointed out above, there is every reason to expect a continuous improvement in the sensitivity of the Iconoscope as time goes by. Eventually, the Iconoscope may equal or even exceed the photographic camera in sensitivity.

Perhaps the most difficult to attain is a satisfactory network of transmitters. At present, the range of an individual transmitter is limited to the visual horizon as seen from its antenna. This means that the area serviced by a transmitter is relatively small, and that each urban center must have its own television transmitters. It is obviously necessary, in a completely satisfactory system, to be able to chain these transmitters in such a way that events can be broadcast nation-wide. These chains will be formed by inter-connecting the stations with means of concentric cable and by the use of radio-relay links.

This ideal system will eventually exist, but only after years of television broadcasting experience. In the meantime, we will have to be content with a much less perfect system. All the units for satisfactory television are ready and now await commercialization by those responsible for the economic and production aspects of the problem. But, as warning to those who are unduly optimistic, the problem of assembling these elements is almost as formidable as that of developing cathode ray television. Universal television in the home will not be an accomplished fact for a number of years to come but, on the other hand, it is absolutely assured that home reception of pictures will eventually be commonplace.

*Registered Trademark of the RCA Manufacturing Co., Inc.

ORDER BLANK

Meissner "BUILD-WITH-SAFETY" KITS

These Meissner "Build-Your-Own" kits represent the triumph of the great Meissner organization. Each kit contains completely matched components such as coils, variable condensers, dials, I.F. transformers and padders, necessary to assure excellent performance of your completed receiver. COMPLETE INSTRUCTIONS and DIAGRAMS with each kit. TUBES EXTRA.

<p>NOISE SILENCER List price \$11.50 Kit No. 7516 456-465 KC <input type="checkbox"/> Kit No. 7517 175 KC</p> <p style="text-align: right;">\$6.76 Net Price</p>	<p>2 TUBE AC-DC PORTABLE 175-550 Meters. A simple set for the beginner. <input type="checkbox"/> List price \$3.50 Kit No. 7513</p> <p style="text-align: right;">\$2.06 Net Price</p>	<p>BEAT FREQUENCY OSCILLATOR List price \$11.50 Kit No. 6350-AC operated <input type="checkbox"/> Kit No. 6370 Battery operated \$2.94</p> <p style="text-align: right;">\$6.76 Net Price</p>	<p>4 TUBE AC-DC TRF METAL TUBE RECEIVER <input type="checkbox"/> List price \$3.50 Kit No. 7524</p> <p style="text-align: right;">\$2.06 Net Price</p>
<p>SHORT WAVE and B.C. "6" METAL TUBE SUPERHET 18-75 and 190-550 Meters <input type="checkbox"/> List price \$15.50 Kit No. 7509</p> <p style="text-align: right;">\$9.12 Net Price</p>	<p>5 TUBE AC-DC METAL TUBE SUPERHET 1510-520 KC <input type="checkbox"/> List price \$14.50 Kit No. 7535</p> <p style="text-align: right;">\$5.59 Net Price</p>	<p>BROADCAST "6" METAL TUBE SUPERHET 175-550 Meters <input type="checkbox"/> List price \$11.25 Kit No. 7506</p> <p style="text-align: right;">\$6.60 Net Price</p>	<p>Metal ALL-WAVE "8" Tube 4 BAND SUPERHETERODYNE 150 to 550 Meters. Including wired and balanced assembly. List price \$28.50 Kit No. 7508 <input type="checkbox"/> Wired and Balanced Assembly only. Kit No. 5760 ... \$7.94</p> <p style="text-align: right;">14.70 Net Price</p>
<p>FREE TO ALL MEISSNER LUCKY "7" CIRCUITS describing the sensational Meissner kits from the 2 Tube AC-DC to the 12 Tube 5 Band receivers.</p> <h2 style="text-align: center;">EAGLE RADIO</h2> <p style="text-align: center;">84 CORTLANDT ST., NEW YORK, N. Y.</p>			

Name
Address
City and State

Hams Will Find These New Tubes Useful

(Continued from page 745)

circuit should be solid copper ribbon about 1/4-inch wide. This of course, should not be soldered to the connector, but secured with a screw. This lead, together with the metal connector at the top of the tube, will help dissipate the heat and avoid the condition mentioned above. Of course, the tank end of the ribbon may be soldered, insofar as the heat is concerned, but this should preferably be bolted in order to reduce R. F. losses to a minimum. —G. W. S.

Eimac 35-T.

(Continued from page 745)

Plate Voltage	Class "C" R.F. (75% eff.)	Class "B" Audio (two tube.)
	500 volts	38 watts
750 volts	56 watts	85 watts
1000 volts	75 watts	115 watts
1250 volts	94 watts	130 watts
1500 volts	112 watts	140 watts

Our information Bureau will gladly supply manufacturers' names and addresses of any items mentioned in Short Wave & Television. Please enclose stamped return envelope.

PAR-METAL RACKS—PANELS—CABINETS

—a size and style for every requirement

PAR-METAL offers you a uniform line of standardized metal products that enable you to quickly build up a job that is professional both in construction and appearance.

THE RACKS, cabinets, panels, etc., are the result of many years experience in making similar equipment for the sound industry. All of these products have been designed and made by a modern plant that has fabricated about everything from a small shield can to the metal work on a broadcast station.

All of the parts are available in various standard sizes—a complete line that will meet almost every requirement.

WRITE FOR COPY OF OUR CATALOG NUMBER 37

PAR-METAL PRODUCTS CORPN.
35-27 41st ST., LONG ISLAND CITY, N. Y.

On broadcast as well as shortwave frequencies, in any location, you can eliminate "man-made" static with

NOISE-MASTER

ALL-WAVE ANTENNA

Send for complete literature.

CORNISH WIRE CO., 30 CHURCH STREET, NEW YORK CITY

RADIOS . . . SAVE 50%

30 DAYS' TRIAL

\$6.95

Discounts up to 50% on NEW 1937 Zephyr Multi-Wide, all-electric, battery and auto radios with all latest improved features. MONEY-BACK GUARANTEE. Write for details of our money-making Agent-User plan and FREE 1937 Catalogue.

ZEPHYR RADIO COMPANY
13135 Hamilton Avenue
Detroit, Michigan

Manufacturers of

VITREOUS TRANSMITTING GRID LEAKS
VOLUME CONTROLS · POWER RHEOSTATS

Write for Complete Free Catalog

ELECTRAD, Inc.
175 Varick Street, New York

Please mention SHORT WAVE & TELEVISION when writing advertisers

Additional Features in New SUPER PRO

(Continued from page 745)

The front bearing is a long self-aligning brass bushing mounted in a circular spring bronze plate to take the thrust of the single ball bearing. These very special bearings afford low resistance contact to the rotor shaft, minimizing interstage coupling.

Another inquiry concerned the input coils. In each band, the input circuit consists of two coils—an antenna or primary coil and a grid or secondary coil. These two coils are effectively shielded from each other electrostatically by a Faraday screen placed between them. Thus the transferred energy from the antenna to the grid is limited to pure electro-magnetic coupling. This particular coil design permits connection to a balanced transmission line having an impedance of 115 ohms. In addition to this coil, are the tuning coils. In the illustration, such a coil is shown and the construction of this as will be noted, is very unusual. A copper disc on an adjusting screw turning in a friction bushing and mounted at the top of each coil form, is used to adjust the inductance for low frequency alignment. High frequency alignment is accomplished by way of a condenser mounted beneath the isolantite base. All the coil forms are of bakelite, the coils for the lowest frequency range being four-bank Litz windings, while the others are space-wound.

In another letter was a request for a detailed description of the crystal filter system. The crystal filter as used in the "Super Pro" provides not only extreme selectivity for C.W. code but when properly adjusted, affords added selectivity for voice and other modulated signals. The crystal holder itself is an isolantite block, ground on both sides to insure an accurate and uniform air-gap above the upper surfacing of the crystal. It is connected in a balanced link circuit coupling the plate circuit of the first detector to the grid circuit of the first I.F. tube. This link circuit has a relatively low impedance to match the series resistance (at resonance) of the crystal. In the other leg of the balanced link circuit, a variable condenser serves to neutralize the capacitance of the crystal and its holder. The insulated shaft of this variable condenser extends through the front panel where a knob and pointer together with an engraved scale permit accurate adjustment to suit various operating requirements. Maximum selectivity suitable for single side band C.W. occurs at or very near the point of exact neutralization which falls at about one (1) on the dial. This setting remains unchanged once found on the particular receiver in operation, unless a new crystal is substituted. By turning the knob toward 10, the band is continuously widened until it is possible to receive voice reception which frequently under interference conditions would not be heard.

The band-spread system works on the three high-frequency bands from 2.5 to 20 megacycles. Below 2.5 megacycles, it is automatically disconnected by the band-change switch. The calibration of the main dial is based on a band-spread dial setting of 100. Decreasing the setting of the band-spread dial decreases the resonance frequency of the receiver. Band-spread may therefore be obtained by setting the main tuning dial to the highest frequency in the desired band. When this has been done, the lower frequencies in the band may be tuned by means of the band-spread dial only.

This receiver definitely fills every specification of the professional operator, providing effective selectivity; sensitivity; band-spread on all the high frequencies; crystal filter; beat frequency oscillator, stand-by switch; tuning meter; AVC or manual control, as well as other manual controls. It is an excellent broadcast receiver too.

This article has been prepared from data supplied by courtesy of Hammarlund Mfg. Co.

See the New Amateur Gear in ALLIED'S NEW SPRING CATALOG

Ready Now—Mail Coupon

NEW! I.P.S. "RUBBER CRYSTAL"

The newest development in X-mitting accessories! Permits continuously variable frequency control with more output than the conventional X-tal oscillator. Can be used with any X-mitter.



NEW! NATIONAL OSCILLOSCOPE

Essential equipment in every Amateur station! Features the RCA-913 tube having a one-inch screen. Efficient and low-priced, it permits checking X-mitter operation in accordance with the new RFC regulations.



NEW! UTAH X-MITTER

Build this inexpensive, dependable unit X-mitter! Operates on 20-40-80 and 160 meter bands. Start with the powerful 60 watt output C.W. X-mitter and build by check stages until you have a complete 12 K.W. phone X-mitter—at low cost!



NEW! HALL-CRAFTERS "SKY-CHALLENGER"

One of the hottest of the new Amateur Communications Receivers. Features five bands—40,000 KC. to 535 KC.—with no gaps; continuous electrical band-spread; iron core I.F.'s; air trimmed I.F.'s; single signal crystal action, etc. Low in price, high in quality.



NEW! RCA-ACR 155

A new communication-type receiver at low price. Includes continuous frequency coverage from 30 to 22,000 KC.; 100-1 selector band-spread tuning drive; large, crank-handled tuning knob; beautiful cabinet; 9 metal tubes, etc.



156 PAGES OF INTEREST FOR EVERY AMATEUR, SERVICEMAN AND DEALER!

Send for your copy of the new Spring 1937 ALLIED Radio Catalog! Its 156 big pages are packed with Everything in Radio—10,000 radio parts; complete lines of Amateur transmitting and receiving gear; test instruments; more than 50 models of the new Knight Radios, featuring Automatic Dialing, AFC, Tone Expansion, etc.; dozens of set-builders' kits; Public Address systems, from 8 to 60 watts; books, tools, etc. You save time, trouble and money when you order from the new ALLIED Catalog!

Are you building—re-building—repairing? Join the Daily Hamfest—write to ALLIED Amateurs. Tell us what you need, what you are doing, what you would like to do. We've been around—we've been building, experimenting and communicating in Amateur Radio since Short Wave's swaddling clothes days... and we like a rag-chew as much as you do. Get in touch with us for all that's new, interesting and important in the Amateur field.

MORE THAN 10,000 RADIO PARTS

The new ALLIED Catalog includes more than 10,000 exact duplicate and replacement parts for constructing or repairing any radio circuit. Write for Free parts lists. We can supply matched kits for building any circuit described in this or any other radio magazine or Handbook. You'll achieve best results when you use ALLIED matched approved parts.



FASTEST SERVICE—LOWEST PRICES

Every Ham knows about ALLIED's low prices (you can't beat 'em!) and speedy service (nix for the swell QSO's about it, fellas!) It's the result of our live Amateur Staff, our complete stocks, and our up-to-date buying and selling methods. We buy for less and pass the savings on to you. Remember—for lowest prices and fastest service "You Can Buy With Confidence at ALLIED—Radio Supply Headquarters!"

READY NOW!
SEND FOR IT!



SEE ALL THESE AND OTHERS IN THIS NEW CATALOG... FREE

The new Spring 1937 ALLIED Radio Catalog includes a complete, comprehensive Amateur section covering everything worthwhile in Ham equipment. Written by Hams and for Hams, it shows the newest Short Wave transmitters, receivers, and transceivers, in factory-built and kit form. Every item shown has been carefully selected by our expert Amateur Staff for quality, dependability and low price. Why shop skimpily, incompletely? Amateur pamphlets? Select your equipment from ALLIED'S new 156 page Catalog—Radio's Most Complete Supply Guide!

ALLIED Radio Corp., Dept. 3-D
833 W. Jackson Blvd., Chicago, Ill.

Rush me your new Spring 1937 Radio Catalog.

Send me parts list for.....

Name

Address

City

Have you a Binder in which to keep your copies of SHORT WAVE and TELEVISION? Order one today—\$1.25. Holds 12 copies. SHORT WAVE and TELEVISION, 99 Hudson St., N.Y.C.

Be kind to your neighbors! Shut off the loudspeaker after 10 P.M.



The favorite set of "Hams"
The phones are built with very heavy but magnets which greatly increase their efficiency.

Use CANNONBALL HEADSETS

You will get clearer reception without disturbing the rest of the family. Write for illustrated circular S-4

C. F. CANNON COMPANY
SPRINGWATER, N.Y.



UNIVERSAL VELOCITY AND CARBON MICROPHONES

Universal's latest achievement—Ideal for stage use—Not affected by temperature or humidity—Flat frequency response curve from 40 to 10,000 c.p.s.; Output 63 db; Low impedance or direct to grid types. Compact 2 3/4 x 3/4 in. by 1 3/4 in. thick—Weight, less than 18 oz.—Iboud swings to any desired angle—Beautifully finished in black enamel and artistic chrome plate—ask for new catalog sheet describing models RL, RP, RH and CB—List \$22.50—Latest model music type sectional stand for above microphones—List \$10.00.

UNIVERSAL MICROPHONE CO., Ltd.
424 Warren Lane Inglewood, Calif., U.S.A.

Please mention SHORT WAVE & TELEVISION when writing advertisers

SHORT WAVE OR BROADCAST . . . YOU'RE THERE with the new 1937 CROSLLEY RADIOS

Exciting and unusual contact with strange worlds in the foreign, aviation and amateur short wave bands . . . crystal-clear reception of the finest entertainment, music and news that the broadcast band has to offer—all of this is yours with the Super-Sensitive 1937 Crosley Radios. These new models bring you not only brilliant world wide reception, but also distinctive beauty in cabinet design and radio's greatest features, including the famous Crosley Auto-Expressionator, Mystic Hand, Cardomatic Unit and ten others. See and hear the new Crosley Radio at your nearest Crosley Dealer today.

POPULAR SHORT WAVE CROSLLEY MODELS



TABLE MODEL 744
7 TUBES Continuous Coverage . . . 16 to 555 meters . . . 6" Speaker . . . 6 watts output . . . Metal Tubes. Dimensions: 15 1/2" high, 14" wide, 9" deep. **\$49.95**



MODEL 759 CONSOLE
7 TUBES Continuous Coverage . . . 16 to 555 meters . . . 12" Speaker . . . 8 watts output . . . Metal Tubes. Dimensions: 30 1/2" high, 24 1/2" wide, 11 1/2" deep. **\$67.50**



MODEL 989 CONSOLE
9 TUBES Continuous Coverage . . . 16 to 555 meters . . . 12" Speaker . . . 12 watts output . . . Metal Tubes . . . Auto-Expressionator. Dimensions: 41 1/2" high, 26" wide, 14 1/2" deep. **\$99.50**

MODEL 1516 CONSOLE
15 TUBES Continuous Coverage . . . 16 to 555 meters . . . 15" Curvilinear Speaker. . . Metal Tubes. . . 25 watts output . . . Auto-Expressionator . . . Mystic Hand. Dimensions: 44 1/2" high, 28" wide, 13 1/2" deep. **\$174.50**

Table Model 745	(16 to 555 m.)	7 tubes	\$ 49.95
Console " 769	(16 to 555 m.)	7 tubes	79.95
" " 1193	(16 to 555 m.)	11 tubes	109.50
" " 1211	(16 to 555 m.)	12 tubes	129.50
" " 1313	(16 to 555 m.)	13 tubes	149.50

(Prices slightly higher in Florida, Rocky Mountain States and west.)

The CROSLLEY RADIO CORPORATION
CINCINNATI, O.

POWEL CROSLLEY, Jr., President

Home of "the Nation's Station"—WLW—70 on your dial—and Short Wave Station W8XAL—49.5 meters.

YOU'RE THERE WITH A **CROSLLEY**

Low-Cost Oscilloscope—

(Continued from page 731)

their own independent power supplies, a degree of versatility is possible which cannot be easily attained when all equipment is in one case.

Although the circuit is quite conventional, some of its features may need a bit of clarification. The two amplifiers are identical in connections, and are simply high-gain types; the use of a small cathode by-pass condenser and an 80 mh. R.F. choke in the plate circuits aiding in attaining linear response over a wide range of frequencies. The vertical amplifier is used only for increasing the voltage of any input connected to the vertical input terminals. The Horizontal amplifier, however, by means of a three-position switch, will amplify either the input from the horizontal terminals, a 60-cycle input from the heater circuit, or the output of the 885 oscillator. Either amplifier can be instantly cut out of the circuit by means of a toggle switch.

The vertical gain control has a single-pole double-throw switch on the back which operates when the potentiometer is turned fully counter-clockwise or "off." It was found that this potentiometer overheats considerably when used for R.F. such as in transmitter measurement work, so it is best to cut it out entirely. It will be necessary to scrape a small portion of carbon from the element at the position occupied by the contact arm when in the full counter-clockwise position. This position may be seen on the circuit diagram and is marked "open." The scraping is easily accomplished with a knife point.

It will be noted that the two input potentiometers are always in circuit, whether the amplifiers are in use or not.

The frequency of the 885 oscillator has a fine and rough control enabling wide variation of its output. A *synchronization control* is also provided, enabling a pattern to be stopped and held indefinitely on the screen as desired. The input for synchronization may be either external, from the binding posts, 60 cycle from the heater circuit, or internal, in which case a small portion of the voltage across the vertical amplifier plate resistor is tapped off. In practice the synchronization control should be run as low as possible, otherwise pattern distortion will result.

The power supply is quite conventional, using a compact, well-shielded transformer and choke. The power transformer has

no 2.5 volt winding, so the 885 heater is run from the 5 volt winding. The necessary voltage drop is provided by a resistor of 1.7 ohms and 10 watt rating. A wire-wound, adjustable 2 ohm unit does the trick.

The bleeder consists of a 50,000 ohm fixed carbon resistor and a wire-wound semi-adjustable unit of the same value. The latter has taps for variation of screen voltage for the 6J7's and cathode voltage for the 885. The former may be set at around 90 V. and the latter at 6 V.

The layout of parts may be seen from reference to the circuit diagram. When fastening the front panel to the chassis be sure to leave about 1/16" so that the bottom of the case can slip in between.

Shielded wire should be used on the input connections and the leads to the other unit. The latter terminate in phone tips for ease of connection.

All condensers in the case, aside from the electrolytics are of the bakelite moulded type, and most of these are the new so-called "domino" condensers. These are really paper condensers moulded into bakelite and are exceptionally compact and handy to use. All parts such as resistors and fixed condensers should be tied down at each end either to socket or other terminals or to lugs on bakelite terminal strips.

If the unit has been wired correctly it must work, as there are no adjustments to make. No space will be taken here to give in detail the way the equipment may be used, as such a description needs a whole volume to do it justice.

It is suggested that the beginner connect a source of 60 cycle A.C. to the vertical posts; anything from 2 to 10 volts is useful. (It may be tapped off either heater circuit if necessary). Then the controls can be manipulated to find just how each affects the pattern. Do not be alarmed if the various controls have a certain degree of interlocking. This is

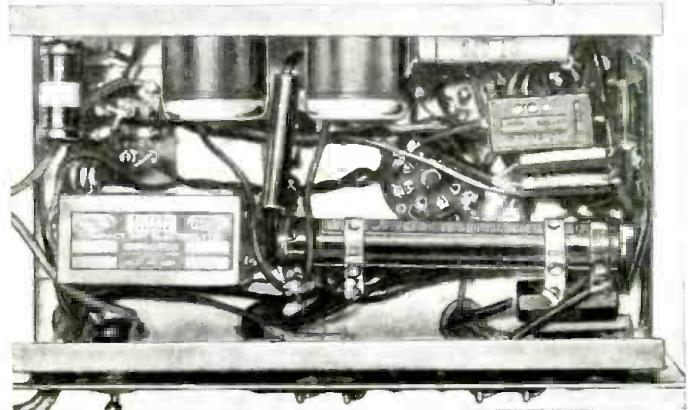
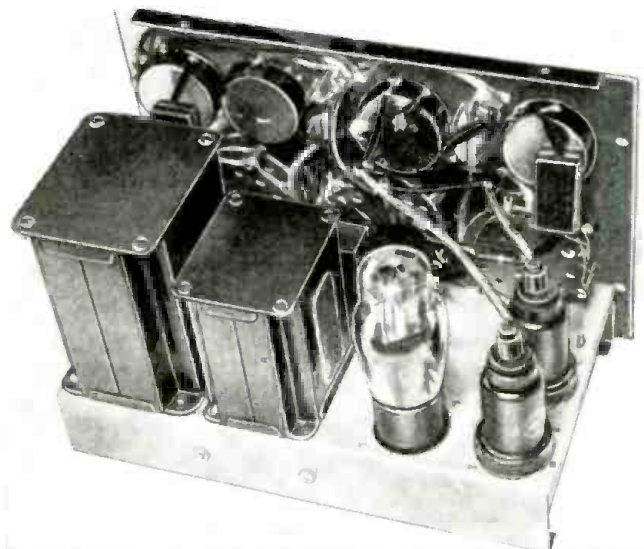

Rear and bottom views of Oscilloscope Attachment.

Please mention SHORT WAVE & TELEVISION when writing advertisers